

User Manual



NetTek YBT1 T1 Circuit Tester

070-9964-01

This document supports firmware version 1.2
and above.

www.tektronix.com

Copyright © Tektronix, Inc. All rights reserved.

Tektronix products are covered by U.S. and foreign patents, issued and pending. Information in this publication supercedes that in all previously published material. Specifications and price change privileges reserved.

Tektronix, Inc., P.O. Box 500, Beaverton, OR 97077

TEKTRONIX, TEK, and NetTek are registered trademarks of Tektronix, Inc.

WARRANTY

Tektronix warrants that the products that it manufactures and sells will be free from defects in materials and workmanship for a period of one (1) year from the date of purchase from an authorized Tektronix distributor. If any such product proves defective during this warranty period, Tektronix, at its option, either will repair the defective product without charge for parts and labor, or will provide a replacement in exchange for the defective product. Batteries are excluded from this warranty.

In order to obtain service under this warranty, Customer must notify Tektronix of the defect before the expiration of the warranty period and make suitable arrangements for the performance of service. Customer shall be responsible for packaging and shipping the defective product to the service center designated by Tektronix, shipping charges prepaid, and with a copy of customer proof of purchase. Tektronix shall pay for the return of the product to Customer if the shipment is to a location within the country in which the Tektronix service center is located. Customer shall be responsible for paying all shipping charges, duties, taxes, and any other charges for products returned to any other locations.

This warranty shall not apply to any defect, failure or damage caused by improper use or improper or inadequate maintenance and care. Tektronix shall not be obligated to furnish service under this warranty a) to repair damage resulting from attempts by personnel other than Tektronix representatives to install, repair or service the product; b) to repair damage resulting from improper use or connection to incompatible equipment; c) to repair any damage or malfunction caused by the use of non-Tektronix supplies; or d) to service a product that has been modified or integrated with other products when the effect of such modification or integration increases the time or difficulty of servicing the product.

THIS WARRANTY IS GIVEN BY TEKTRONIX WITH RESPECT TO THE LISTED PRODUCTS IN LIEU OF ANY OTHER WARRANTIES, EXPRESS OR IMPLIED. TEKTRONIX AND ITS VENDORS DISCLAIM ANY IMPLIED WARRANTIES OF MERCHANTABILITY OR FITNESS FOR A PARTICULAR PURPOSE. TEKTRONIX' RESPONSIBILITY TO REPAIR OR REPLACE DEFECTIVE PRODUCTS IS THE SOLE AND EXCLUSIVE REMEDY PROVIDED TO THE CUSTOMER FOR BREACH OF THIS WARRANTY. TEKTRONIX AND ITS VENDORS WILL NOT BE LIABLE FOR ANY INDIRECT, SPECIAL, INCIDENTAL, OR CONSEQUENTIAL DAMAGES IRRESPECTIVE OF WHETHER TEKTRONIX OR THE VENDOR HAS ADVANCE NOTICE OF THE POSSIBILITY OF SUCH DAMAGES.



Table of Contents

General Safety Summary	iii
Battery Recycling	v
Preface	vii
About This Manual	vii
Online Help Information	vii
Conventions	viii
Software Version	viii
Contacting Tektronix	ix

Getting Started

Product Description	1-1
Installing NetTek YBT1 Software	1-5
Assembling the PC Card and Line Interface	1-5
Installing the PC Card	1-6
Securing the Cables	1-8
Powering On the Tester	1-9
Starting the NetTek YBT1 Software	1-9
Performing a Functional Check	1-10
Powering Off the Tester	1-10
Understanding the Power Switch	1-11
Preventing Personal Injury from the Effects of Lightning	1-12

Operating Basics

Overview	2-1
Identifying Front-Panel Controls and Indicators	2-2
Navigating the Desktop	2-3
Entering Text	2-6
Getting Help	2-7
Using the Main Controls	2-8
Menus	2-9
Toolbar Buttons	2-11
Configuration Buttons	2-12
Instrument Settings	2-18
Understanding the Summary Window	2-19

Understanding the Alarms Window	2-20
Understanding the Errors Window	2-23
Understanding the History Window	2-26

Reference

Connecting to a Signal	3-1
Making a Monitor Connection	3-1
Making a Bridge Connection	3-3
Making a Terminate Connection	3-4
Making a Loopback Connection	3-6
Testing a Circuit	3-7
Selecting Settings	3-9
Setting the Alarms and Errors Rolling Display Data	
Collection Resolution	3-12
Using the DS0 View	3-13
Setting the DS0 Data Collection Update Time Interval ...	3-14
Performing an Automated Test	3-15
Setting Up a Far End Loop	3-19
Setting Up a Loop Code	3-20

Appendices

Appendix A: Specifications	A-1
Appendix B: Accessories	B-1
Standard Accessories	B-1
Optional Accessories	B-2
Appendix C: Diagnostic Self Tests	C-1
Test Descriptions	C-3
Appendix D: Installing NetTek YBT1 Software	D-1
PC Requirements	D-1
Installing Using a Serial Connection	D-1
Installing Using an Archive File	D-3

Index

General Safety Summary

Review the following safety precautions to avoid injury and prevent damage to this product or any products connected to it. To avoid potential hazards, use this product only as specified.

Only qualified personnel should perform service procedures.

While using this product, you may need to access other parts of the system. Read the *General Safety Summary* in other system manuals for warnings and cautions related to operating the system.



WARNING. *To avoid injury, do not connect this product to any source which may be subject to the effects of lightning. See page 1-12 for complete information.*

To Avoid Fire or Personal Injury

Use Proper Power Cord. Use only the power cord specified for this product and certified for the country of use.

Observe All Terminal Ratings. To avoid fire or shock hazard, observe all ratings and markings on the product. Consult the product manual for further ratings information before making connections to the product.

Replace Batteries Properly. Replace batteries only with the proper type and rating specified.

Recharge Batteries Properly. Recharge batteries for the recommended charge cycle only.

Use Proper AC Adapter. Use only the AC adapter specified for this product.

Do Not Operate Without Covers. Do not operate this product with covers or panels removed.

Avoid Exposed Circuitry. Do not touch exposed connections and components when power is present.

Wear Eye Protection. Wear eye protection if exposure to high-intensity rays or laser radiation exists.

Do Not Operate With Suspected Failures. If you suspect there is damage to this product, have it inspected by qualified service personnel.

Do Not Operate in an Explosive Atmosphere.

Safety Terms and Symbols

Terms in This Manual. These terms may appear in this manual:



WARNING. *Warning statements identify conditions or practices that could result in injury or loss of life.*



CAUTION. *Caution statements identify conditions or practices that could result in damage to this product or other property.*

Terms on the Product. These terms may appear on the product:

DANGER indicates an injury hazard immediately accessible as you read the marking.

WARNING indicates an injury hazard not immediately accessible as you read the marking.

CAUTION indicates a hazard to property including the product.

Symbols on the Product. These symbols may appear on the product:



CAUTION
Refer to Manual

Battery Recycling

This product contains a Lithium-Ion battery, which must be recycled or disposed of properly. For the location of a local battery recycler in the U.S. or Canada, please contact:

RBRC
Rechargeable Battery Recycling Corp.
P.O. Box 141870
Gainesville, Florida 32614

(800) BATTERY
(800) 227-7379
www.rbrc.com



Preface

This manual contains setup and operating instructions for the NetTek YBT1 T1 Circuit Tester.

About This Manual

This manual is divided into four sections: *Getting Started*, *Operating Basics*, *Reference*, and *Appendices*.

The *Getting Started* section explains how to install and start up your T1 Circuit Tester.

The *Operating Basics* section explains how to operate the tester.

The *Reference* section explains how to perform tests.

The *Appendices* contain reference information you might need occasionally, such as specifications or diagnostic procedures.

Online Help Information

The NetTek YBT1 online help provides detailed information on operating the tester. The online help is the first place you should look for this kind of information.

The NetTek YBT1 tester runs on the Y350 NetTek Analyzer Platform. You will find important information on configuring and operating this platform in the *Y350 NetTek Analyzer Platform User Manual*, Tektronix part number 071-0805-XX. Additionally, the analyzer platform supplies its own built-in online help.

Conventions

This manual uses the following convention to document the commands you must use to operate the NetTek YBT1 T1 Circuit Tester..

The statement **Start > Help** is asking you to open the Start menu and select Help. To accomplish this, tap the **Start** button in the toolbar at the bottom of the desktop window; then tap **Help** in the resulting menu.

Software Version

This manual supports products running software Version 1.2 and above.

To verify your software version, do the following:

1. In the toolbar at the top of the startup screen, select **Tools**.
2. Select **Software Info** from the menu.

Contacting Tektronix

Phone	1-800-833-9200*
Address	Tektronix, Inc. Department or name (if known) 14200 SW Karl Braun Drive P.O. Box 500 Beaverton, OR 97077 USA
Web site	www.tektronix.com
Sales support	1-800-833-9200, select option 1*
Service support	1-800-833-9200, select option 2*
Technical support	Email: techsupport@tektronix.com 1-800-833-9200, select option 3* 6:00 a.m. - 5:00 p.m. Pacific time

* **This phone number is toll free in North America. After office hours, please leave a voice mail message. Outside North America, contact a Tektronix sales office or distributor; see the Tektronix web site for a list of offices.**



Getting Started



Getting Started

This section provides the information you need to set up the NetTek YBT1 T1 Circuit Tester:

- Installing software
- Assembling the product
- Installing the PC card
- Starting the software
- Performing a functional check

Product Description

The NetTek YBT1 T1 Circuit Tester is part of the NetTek BTS Field Tool family: a high-performance, portable, field-ready tester, optimized for rapid troubleshooting and base station performance verification.

The NetTek YBT1 compliments the functionality of the YBT250 NetTek Field Transmitter and Interference Tester and YBA250 Antenna and Transmission Line Analyzer modules, which also operate on the Y350 NetTek Analyzer Platform.

Use the NetTek YBT1 to ensure the proper operation of T1 data lines by verifying synchronization, line framing, bit errors, and other important characteristics. The NetTek YBT1 circuit tester can perform measurements on both in-service and out-of-service networks, in order to support communications industry customer requirements.

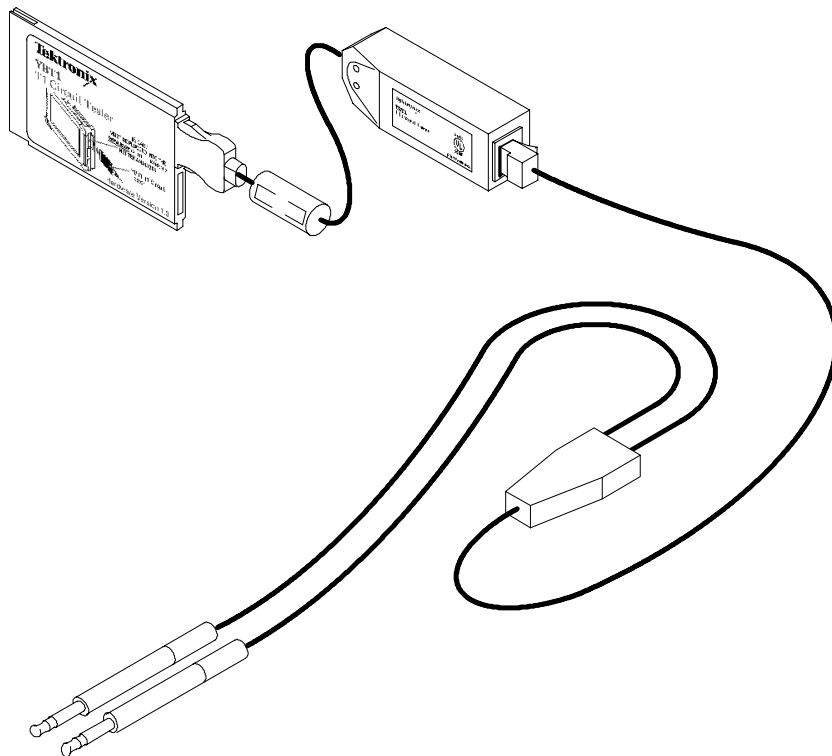

Figure 1-1: The NetTek YBT1 T1 Circuit Tester

Product Features

The NetTek YBT1 T1 Circuit Tester features include the following;

- Standards and technology compliance: T1.402, T1.403, G.703
- Line coding compatibility: AMI, B8ZS
- Frame format compatibility: D4 Superframe and ESF
- Connection configurations: single-port monitor, bridge, terminate, receive-to-transmit loopback
- Line impedance: monitoring (100 Ω), terminating (100 Ω), bridging (1 k Ω)



- Receive level measurement
- Status indicators: T1 pulses, frame synchronization, BER (Bit Error Rate), pattern synchronization
- Line code detection: AMI and B8ZS
- Error detection: bit errors, bit-error rate, frame errors, bipolar violations, cyclic redundancy check errors, errored seconds
- Alarm reporting: carrier loss, frame loss, pattern synchronization loss, AIS/Blue, RAI/Yellow, excessive zeros, ones density failure
- Counters: BERT pattern errors, bipolar violations, frame errors, CRC errors
- DS0 Drop: visual display of ones density and audio monitoring
- User-definable transmission levels
- Transmission timing: internal or recovered
- Error insertion: single bit error, single bipolar violation (BPV), single frame error, single cyclic redundancy check (CRC) error
- Bit Error Rate Test patterns: QRSS, All Zeros, All Ones, 1-in-7, 2-in-8, 3-in-24, T1-1 (Min/Max), T1-2 (Trip Test), T1-3 (54-Octet), T1-4 (120 Octet), T1-5 (53 Octet), T1-6 (55 Octet)
- Automated testing: frame mode detection, line coding detection, CRC-6 error sensing, timed test, BER-pattern sequence
- Loop code transmission

Components and Accessories

Table 1-1 contains general information on YBT1 T1 Circuit Tester components and accessories.

For a complete list of standard and optional accessories, see *Appendix B*, beginning on page B-1.

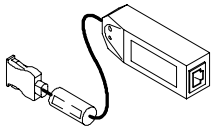
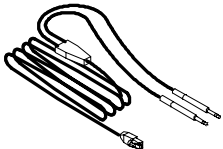
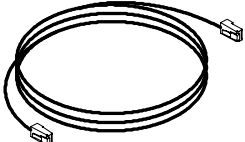
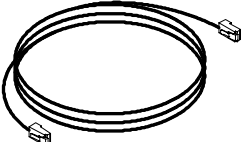
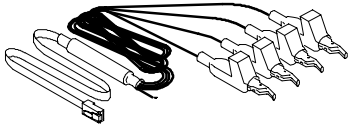
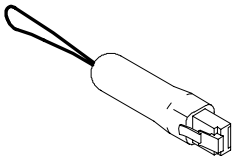
Table 1-1: Components and accessories

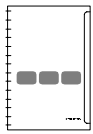
	<p>YBT1 PC Card. Acts as the product platform and provides a T1 digital interface to the Y350 NetTek Analyzer Platform. See page B-1 for replacement information.</p>
	<p>T1 Line Interface. Adapts the PC card interface to RJ48 test cables. See page B-1 for replacement information.</p>
	<p>RJ48-to-Bantam Y Cable. Provides a RJ48-compatible connection between the T1 Line Interface and a DSX patch panel. See page B-1 for replacement information.</p>
	<p>RJ48-to-RJ48 Straight-Wired Cable. Provides a RJ48-compatible connection between the T1 Line Interface and base station equipment. See the list of optional accessories on page B-2 for ordering information.</p>
	<p>RJ48-to-RJ48 Cross-Wired Cable. Provides a RJ48-compatible connection between the T1 Line Interface and the base station NIU (Network Interface Unit). See the list of optional accessories on page B-2 for ordering information.</p>
	<p>RJ48-to-Alligator Clip Cable. Provides a connection between the T1 Line Interface and the internal wiring of base station equipment. See the list of optional accessories on page B-2 for ordering information.</p>
	<p>RJ48 Loopback Plug. Connects the NetTek YBT1 receive input to the NetTek YBT1 transmit output when plugged into the T1 Line Interface. Required to run the diagnostic self tests. See page B-1 for replacement information.</p>
	<p>Installation Software CD-ROM. Installs NetTek YBT1 software on the Y350 NetTek Analyzer Platforms from a desktop computer. See page B-1 for replacement information.</p>
	<p>User Manual. Provides setup and basic operating information. (The CD-ROM is packaged inside the user manual.) See page B-1 for replacement information.</p>

Installing NetTek YBT1 Software

If you purchased a Y350 NetTek Analyzer Platform and NetTek YBT1 directly from Tektronix, the T1 Circuit Tester software is already installed and the tester is ready to operate.

NetTek YBT1 Field Tool Software Purchased Separately

If you purchased NetTek BTS Field Tools previously and are adding a NetTek YBT1 T1 Circuit Tester, follow the procedure on page D-1 to install the NetTek YBT1 software on the Y350 NetTek Analyzer Platform.

Software Upgrades

To upgrade or reinstall NetTek YBT1 software on the Y350 NetTek Analyzer Platform, follow the procedure on page D-1.

Assembling the PC Card and Line Interface

1. Connect the PC card to the T1 Line Interface. See Figure 1-2.
2. Connect the RJ48 cables best suited to your individual test needs to the line interface.

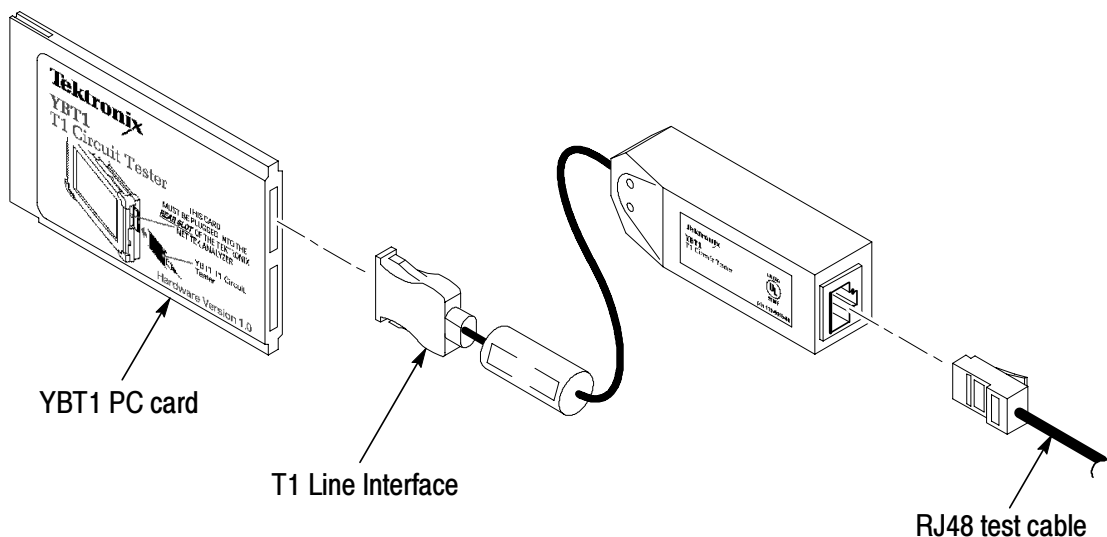

Figure 1-2: Assembling the NetTek YBT1

Installing the PC Card

Use the following procedure to install the NetTek YBT1 PC card in the Y350 NetTek Analyzer Platform.



CAUTION. *To meet the electromagnetic emissions standards specified for this product, install the NetTek YBT1 PC card in the rear slot of the NetTek Analyzer Platform. See Figure 1-3.*

In addition, do not install any other PC card while using the NetTek YBT1 card.

1. Place the NetTek Analyzer Platform on a flat surface with the touch-screen display facing towards you.
2. Open the PC card access door on the right side of the analyzer. See Figure 1-3.
3. Slide the PC card into the rear PCMCIA slot as shown in Figure 1-3. Make sure the Tektronix side of the label faces toward the display.
4. Press in firmly to seat the PC card connector.
5. To release the card later, press the button at the top of the card slot.

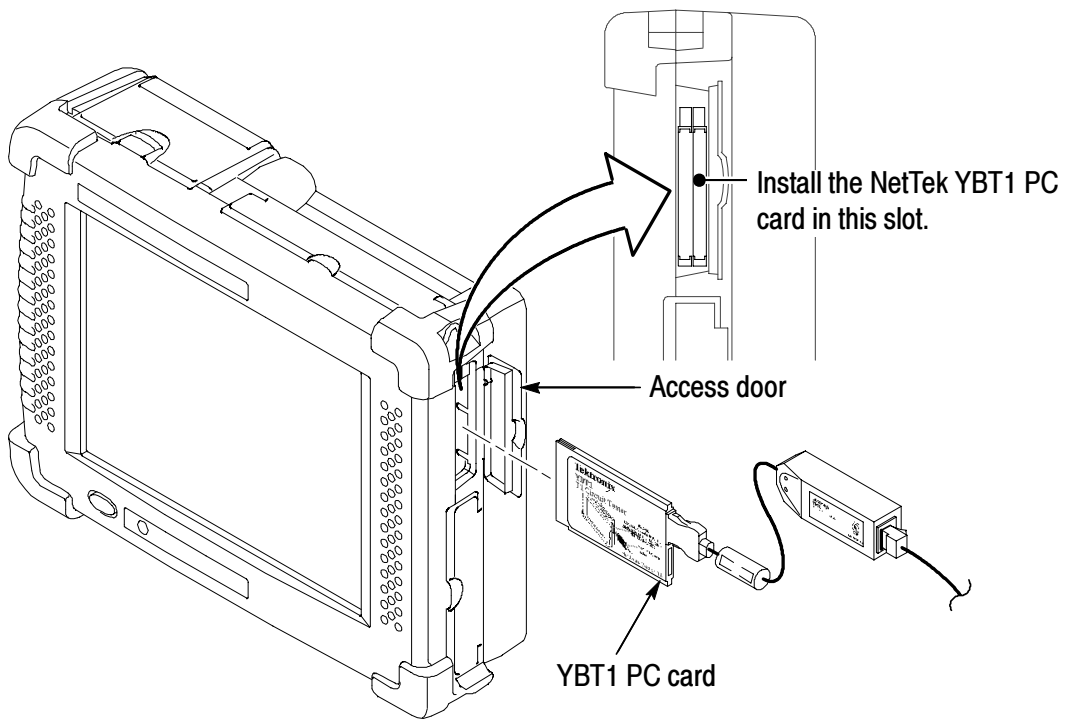

Figure 1-3: Installing the PC card

Securing the Cables

To prevent damage to the PC card and T1 line interface connections by overextending the cables, you may want to secure the line interface to the side of the Y350 NetTek Analyzer Platform with the included Velcro strips. See Figure 1-4.

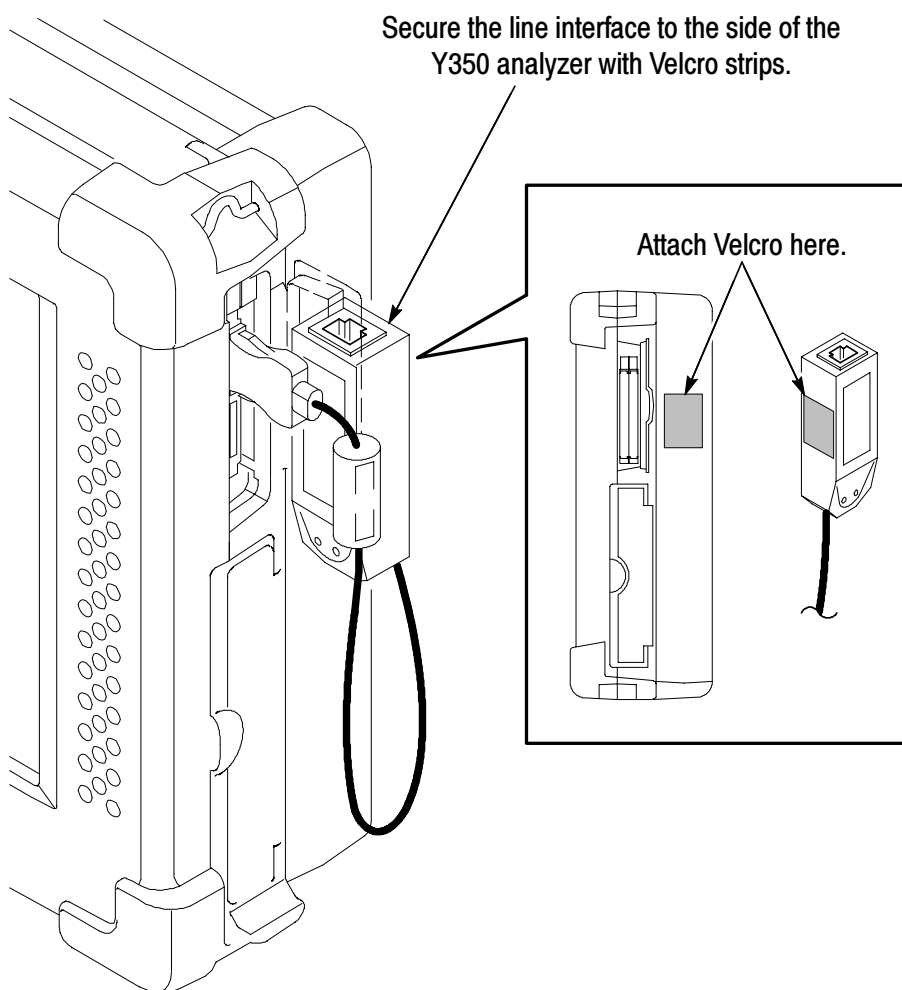

Figure 1-4: Attaching the line interface to the Y350 NetTek Analyzer Platform

Powering On the Tester

Press the large blue oval button in the lower-left corner of the Y350 NetTek Analyzer Platform. The power status indicator illuminates immediately. Allow approximately one minute for the analyzer platform to complete the power-on sequence.

Starting the NetTek YBT1 Software

You have the following options to start up the NetTek YBT1 measurement software:

- Double-tap the **YBT1** application icon on the NetTek Analyzer Platform desktop if present. The shortcut icon must be previously created by the user or set up at the factory.
- Select **Start > Programs > NetTek > YBT1** in the taskbar.
- Depending on the configuration of your NetTek Analyzer Platform, the NetTek YBT1 software can start up automatically at power on.

Configure the NetTek YBT1 to Start Up Automatically

Use the following procedure to configure the NetTek Analyzer Platform to start up the NetTek YBT1 software at power on.

1. Select **Start > Programs > Windows Explorer**.
2. Navigate to the `Windows\Programs\NetTek` directory.
3. Select **YBT1 (Shortcut)** in the NetTek directory.
4. In the menu bar, select **Edit > Copy**.
5. Navigate back to the `\Windows` directory by tapping the left arrow in the menu bar.
6. Open the Startup folder.
7. In the menu bar, select **Edit > Paste Shortcut**.

Performing a Functional Check

Following installation and start up of the NetTek YBT1 software, perform the following procedure to verify that the T1 Circuit Tester is functioning properly.

1. Insert the RJ48 Loopback Plug into the T1 Line Interface as shown in Figure 1-5.
2. Perform the diagnostic tests on page C-1.

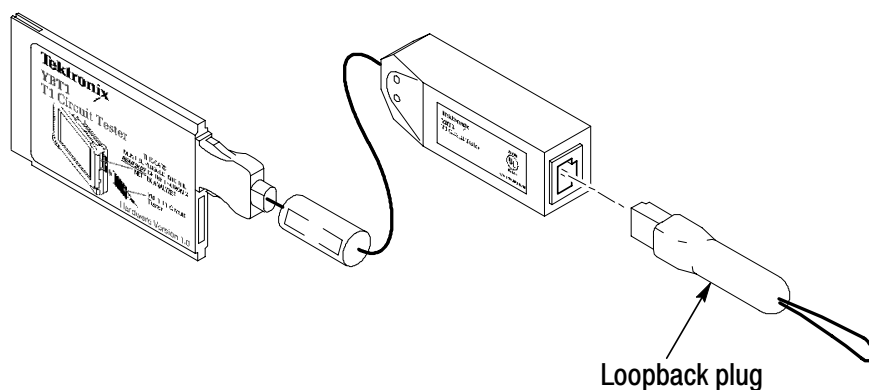

Figure 1-5: Inserting the Loopback Plug into the T1 Line Interface

Powering Off the Tester

The NetTek YBT1 has separate, interrelated, standby and power off functions.

Suspend Mode

Use Suspend mode to place the NetTek YBT1 in a suspended (standby/sleep) state. This is the typical power down mode that allows the NetTek YBT1 software to remain in volatile memory. If the NetTek YBT1 remains in Suspend mode for an extended time (approximately two hours), it will automatically enter Shutdown mode.

To suspend NetTek YBT1 operations, choose one of the following methods:

- Press the front-panel power switch.
- Select **Start > Shutdown**. In the Shut Down dialog box, select **Suspend**.

To cancel Suspend mode and wake up the NetTek YBT1, press the front-panel power switch. The NetTek YBT1 will return to the operating state that existed before suspend mode was invoked.

Shutdown

To completely power down the NetTek YBT1, do the following:

1. Select **Start > Shutdown**.
2. In the Shut Down dialog box, select **Shutdown**.

The next time you press the front-panel power switch, the NetTek YBT1 will cycle through the complete power up process, which takes approximately two to three minutes.

Restart (Software Reset)

To reset the NetTek YBT1 software:

1. Select **Start > Shutdown**.
2. In the Shut Down dialog box, select **Restart**.

The display blanks for approximately five seconds. The NetTek YBT1 software will reload and start up.

Understanding the Power Switch

Depending on the current state of the NetTek YBT1, pressing the front-panel power switch performs one of the following functions:

- If the NetTek YBT1 is shut down: powers on the instrument.
- If the NetTek YBT1 is operating: initiates Suspend mode.
- If the NetTek YBT1 is in Suspend mode: cancels Suspend mode and activates the NetTek YBT1.

- If the NetTek YBT1 is in PowerSaver mode (touch-screen display off): activates the display.

Preventing Personal Injury from the Effects of Lightning



WARNING. *To prevent personal injury from the effects of lightning, exercise the following precautions when using this product.*

Before connecting this product to any source

- Be sure there is no lightning in your vicinity.
- Check your local weather forecast for the possibility of thunderstorms or lightning.
- If weather conditions could allow thunderstorms or lightning to develop, be sure to visually check the sky and weather conditions in your area frequently.
- If you hear thunder or see lightning, do not connect this product to any source that may be exposed to the effects of lightning.
- Use your own good judgement and common sense. You must protect yourself from the effects of lightning.
- You must assume that hazardous voltages will be present on exposed surfaces of this product if it is connected to a source exposed to lightning. The insulation of this product will not protect you from these hazardous voltages.

Do not connect this product to any source that might be subject to the effects of lightning

If thunderstorms or lightning are in your vicinity:

- When weather conditions that could lead to lightning activity exist in your area, ***you could be at risk of a lightning strike*** before the cloud is close enough for you to hear thunder or see lightning.

- When lightning strikes a structure or facility, current travels through the rebar, concrete, pipes, cables, vent stacks, and electrical system.
- Lightning can induce electric and magnetic fields into structures and portions of wiring. The length of a conductor affected by the magnetic field of a lightning strike may exceed two miles.

Be alert and aware of the effects of lightning

- When lightning strikes a conductor, which in turn introduces current into an area some distance from the ground strike point, *equipment can be damaged and personnel injured* if they become an indirect path in the completion of the ground circuit.
- Conductors such as the braided shields of cables or unshielded wire, will have significant transient currents flowing in them in regions exposed to the electric field effect of lightning.
- Induced voltages may cause breakdown of insulation in wiring at connectors and in electrical components, or breakdown of air.



Operating Basics

Operating Basics

This section provides the information you need to operate the NetTek YBT1 T1 Circuit Tester:

- Identifying the front-panel controls
- Navigating the desktop
- Entering text with the soft keyboard
- Getting help
- Understanding the test windows

Overview

The NetTek YBT1 is a member of the Tektronix NetTek Series of modular instruments. A NetTek Series instrument consists of a hardware module, application software, and the Y350 NetTek Analyzer Platform. NetTek Series instruments can be purchased with or without the NetTek Analyzer Platform.

The NetTek Analyzer Platform consists of a specialized Windows CE-based computer and display. It is also the power source for all NetTek Series hardware modules. The hardware module for each instrument consists of analysis circuitry that works in conjunction with application-specific software, which provides the instrument interface and analysis capability.

The NetTek YBT1 is equipped with a touch-screen display and stylus. Use the stylus as you would the mouse on your desktop computer. You can select an object by tapping it, move it by dragging it, or activating it by double-tapping it.



CAUTION. Only use soft objects, such as plastic or your finger, to tap the touch-screen display. Do not use metal or other abrasive materials as they will damage the display surface.

Identifying Front-Panel Controls and Indicators

The front-panel controls power the NetTek Analyzer Platform on and off, reset the analyzer, and indicate operating status.

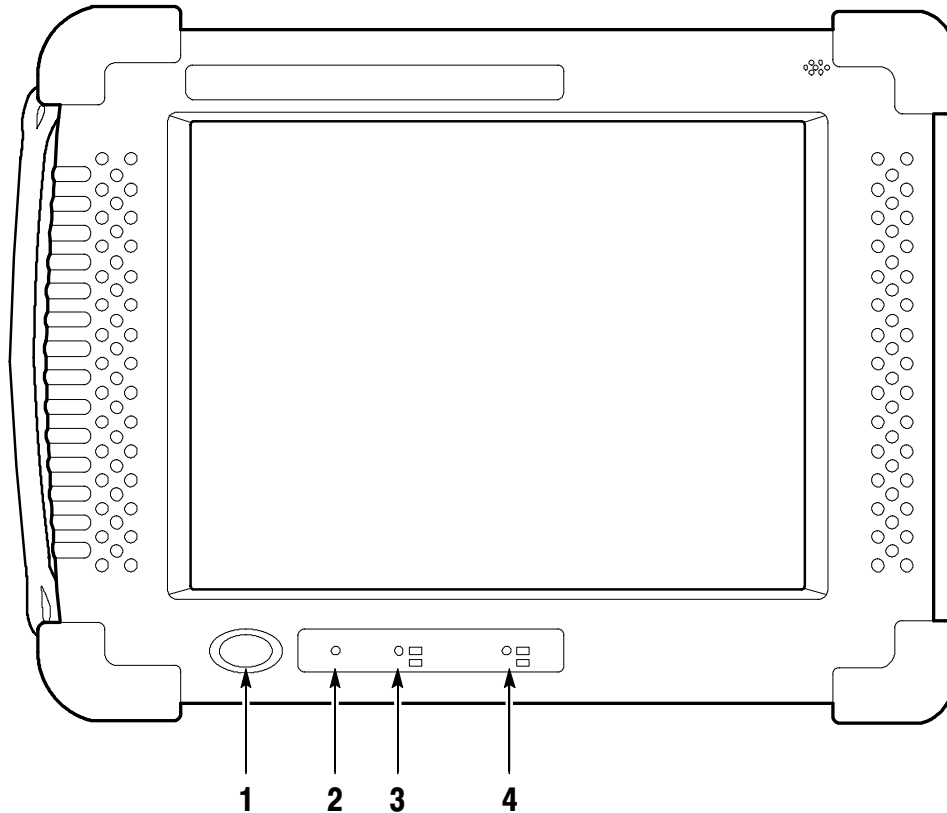

Figure 2-1: NetTek Analyzer Platform front-panel controls and indicators

1. **Power/Suspend Switch.** Push on; push off. See pages 1-9 and 1-10 for additional information.
2. **Reset Switch.** Push to perform a hardware reset if the tester locks up. Programs and other data loaded into volatile memory since startup will be lost.

3. **Status Indicator.** Green indicates power on. Amber indicates display off PowerSaver mode.
4. **Batteries Indicator.** Green indicates the instrument is connected to an external power source and charging a battery, if installed. Red indicates a low battery.

Navigating the Desktop

The NetTek Analyzer Platform desktop is your primary workplace. Use the desktop to configure hardware and software, adjust settings, establish communications, and access application software.

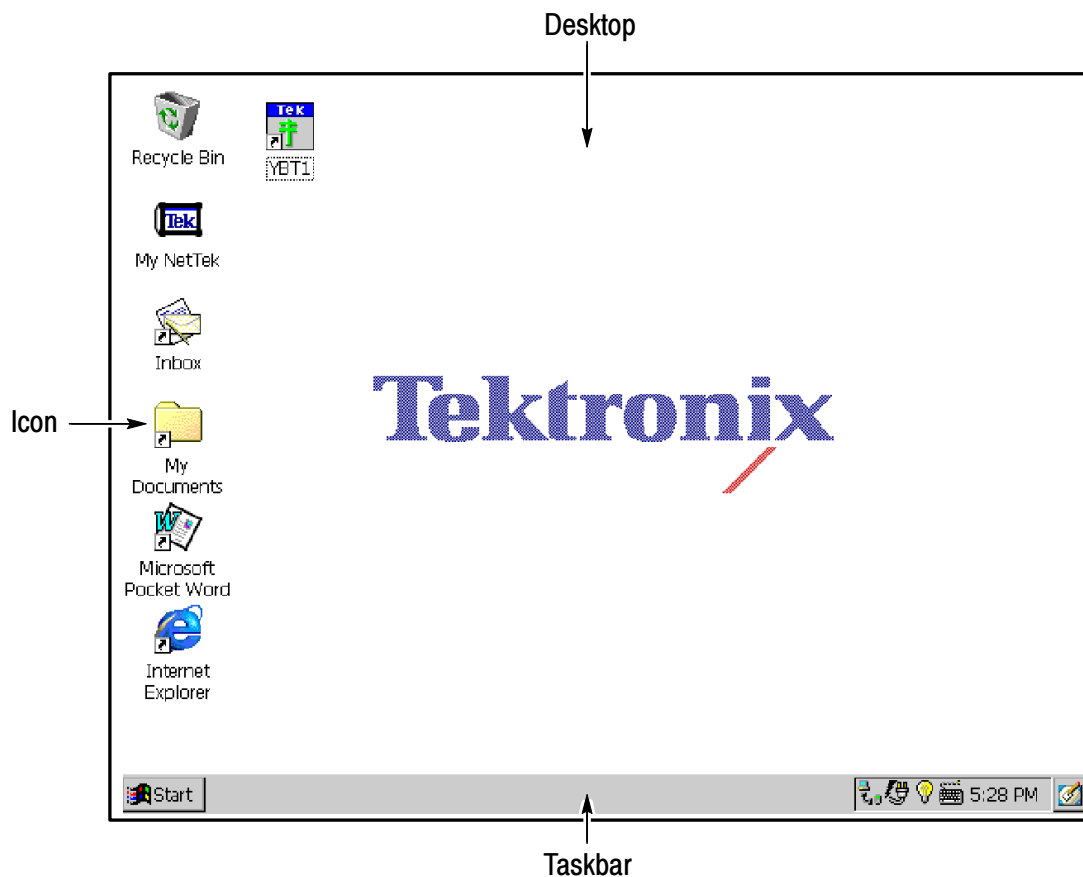

Figure 2-2: NetTek Analyzer Platform desktop

Icons

Double-tap on desktop icons to open folders or to start programs.

Taskbar

The Taskbar contains the Start menu, buttons to minimize the programs you are running, a status area, and a return to desktop button.

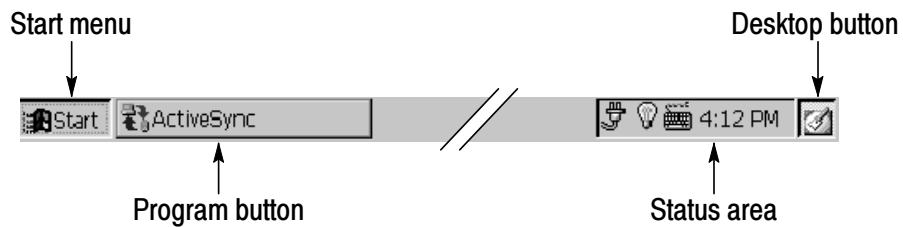

Start Menu. Use the Start menu to load and run instrument modules and other programs, access settings, open documents, and obtain help. Select (tap) **Start** to open the menu; then select the entry you want.

For detailed information on Start menu selections, see the *Y350 NetTek Analyzer Platform User Manual*.

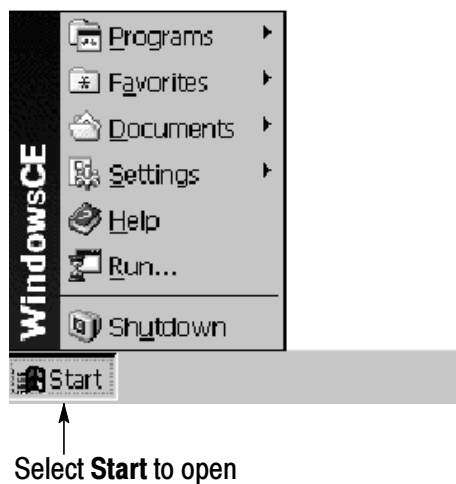





Desktop Button. Tap the desktop button to minimize all running programs and display the desktop.

Program Buttons. To minimize a program that is running, select its taskbar button. To restore the program, select the button again.

Status Area. Icons and buttons appearing in this area indicate status, activate features, or open settings windows. Double-tap the icons for further information.

Table 2-1 explains the function of some common status icons. For a complete list and explanation of all status area icons, refer to the NetTek Analyzer Platform online help. Select **Start > Help**. In the help window select **Windows CE Basics**; then select **Understanding Taskbar Icons**.

Table 2-1: Status area icons

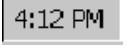
Tap icon	To	Details
	Double-tap to open the Power Management utility.	The analyzer is operating on external AC power.
	Double-tap to open the Power Management utility.	The analyzer is charging batteries.
	Double-tap to open the Power Management utility.	The analyzer is operating on battery power. Also indicates charge level.
	Double-tap to open the Backlight utility.	Adjust the backlight brightness.
	Single-tap to open the Input Panel soft keyboard.	Single-tap to close the keyboard.
	Double-tap to open the Date/Time utility.	Set the date and time.

Entering Text

Use the NetTek Analyzer Platform soft keyboard to type characters into text boxes or address fields without using an external keyboard.

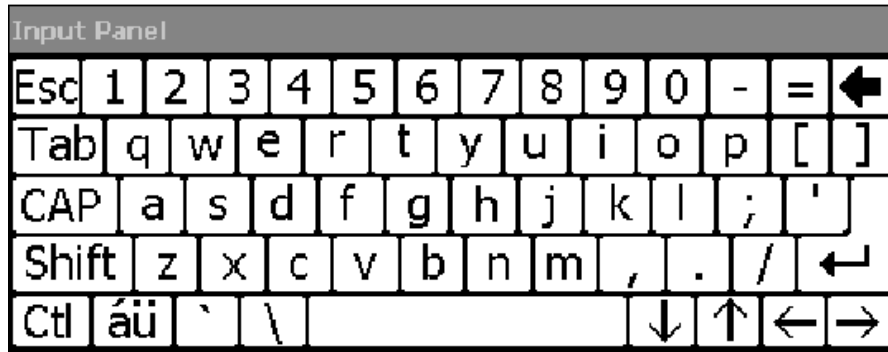



Figure 2-3: Soft keyboard

1. Tap the  icon in the toolbar status area.
2. Tap the Input Panel keys to enter text.
3. Tap  (RETURN) to wrap text or execute a command.
4. Tap the keyboard icon to close the keyboard.

To set soft keyboard properties, select **Start > Settings > Control Panel**. Open the Input Panel icon, and then select **Options**.

Special Characters

The soft keyboard includes characters not visible on the startup keyboard.

CAP Key. Tap the **CAP** (lock) key to create all capital letters and common characters.

Shift Key. Tap the **Shift** key to create a single capital letter or common character.

AU Key. Tap the  key to create special characters.

Getting Help

To open the Help Contents menu on the Y350 NetTek Analyzer Platform, select **Start > Help** in the Taskbar.

To open the Help window and obtain information on T1 Circuit Tester topics, select **Help** from the Start menu; then select **ybt1**.

Use the following methods to obtain help while running the T1 Circuit Tester:

- Tap the  icon in the upper-right corner of the touch screen to display the top level of NetTek YBT1 help.
- Tap underlined text to display information on a specific topic.
- Tap the **Help** button in a dialog box, if present, to display task-specific information.

The Help Window

Table 2-2 explains how to use the Help window buttons.

Table 2-2: Help window buttons









Tap this button	To
 All Topics	Display the NetTek Analyzer Platform main table of contents.
 Back	Return to the previous help screen.
 Contents	Display the current program or local table of contents.
	Display full-screen help text.
	Display the help text in its own window. Tap and drag the Help window title bar to move the window.
	Close the Help window. To reopen, tap the Help icon in the taskbar.
	Close the Help window and quit help.

Table 2-2: Help window buttons (Cont.)

Tap this button	To
	Scroll the text towards the bottom of the screen.
	Scroll the text towards the top of the screen.

Using the Main Controls

Figure 2-4 shows the basic controls available in the test windows.

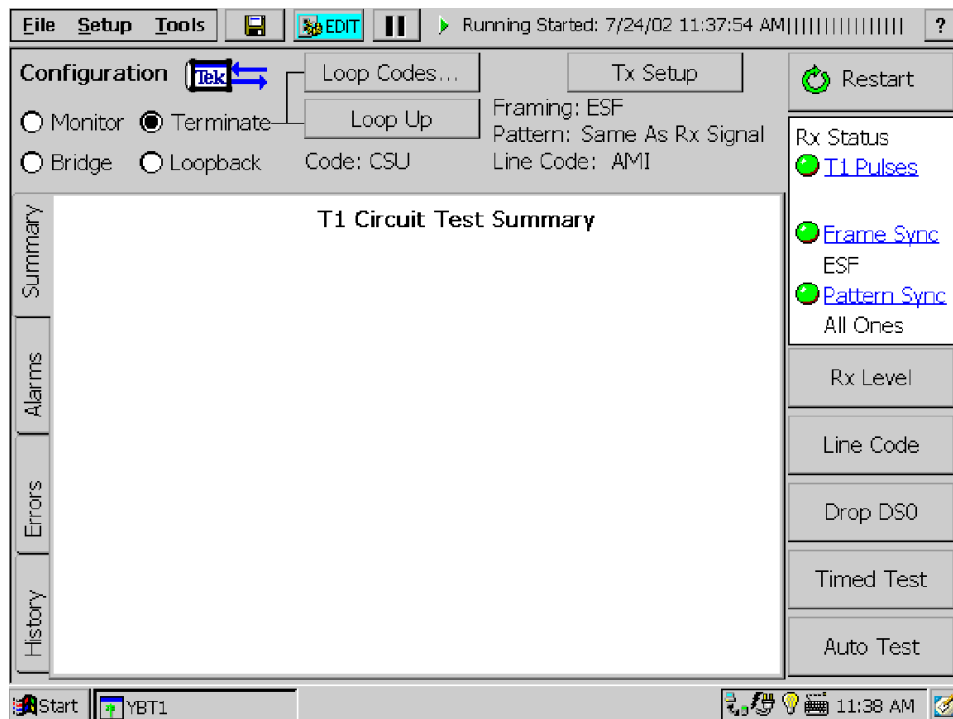

Figure 2-4: NetTek YBT1 main controls

Menus

Table 2-3 lists the available menu selections.

Table 2-3: NetTek YBT1 menu selections

Menu	Function or description
File >	
Open	Invokes the <i>Open</i> dialog box to select and open a previously saved *.nr0 results file.
Open Last Results	Recalls the results of the previous test, or data collected since the last Restart.
Save Results	Saves the results of the current test. Uses identical settings as the previous <i>Save Results As</i> and <i>Settings > Save and Export</i> dialog boxes.
Save Results As	Saves the current test results as specified by the <i>Save As</i> and <i>Settings > Save and Export</i> dialog boxes.
Export Results As	Invokes the <i>Save As</i> dialog box to save results as a tab-separated or comma-separated file for export by the NetTek Analyzer Platform.
Export Screen As	Invokes the <i>Save As</i> dialog box to save screens as PNG, JPEG, or Bitmap files for export by the NetTek Analyzer Platform.
Print	Invokes the <i>Print</i> dialog box to print the current screen.
Results Properties	Lists the <i>Settings > Save and Export</i> properties and user notes to be saved with the current results file.
Exit	Closes the NetTek YBT1 application.









Table 2-3: NetTek YBT1 menu selections (Cont.)

Menu	Function or description
Setup >	
Edit	Invokes the <i>Settings</i> dialog box to change or configure instrument settings.
Open	Invokes the <i>Open</i> dialog box to execute *.sav files for changing instrument settings.
Save	Invokes the <i>Save As</i> dialog box to save current instrument settings as a *.sav file.
Preset	Returns the NetTek YBT1 to factory default settings.
Tools >	
Options	Opens the <i>Setup Menu</i> dialog box to show/hide and protect instrument settings.
Keyboard	Invokes the on-screen soft keyboard to enter alphanumeric characters into entry fields and dialog boxes.
Touchscreen Calibration	Invokes the <i>Stylus Properties</i> dialog box for calibrating the touch-screen display.
Upgrade Software	See Appendix D for software upgrade instructions.
Technical Support	Displays information on how to contact Tektronix.
Software Info	Displays the NetTek YBT1 software version and other properties.
Hardware Info	Displays NetTek YBT1 hardware properties.

Toolbar Buttons

Table 2-4 shows the toolbar buttons and explains their function.

Table 2-4: Toolbar icons

Tap this icon	To	Details
	Open the File menu	Save or export results and screens; exit the software.
	Open the Setup menu	Edit settings; access or save user data; return to factory default settings.
	Open the Tools menu	Configure option settings; open the keyboard; calibrate the touch screen; obtain hardware and software version information.
	Save results (File > Save Results)	Save current results to default file location. ¹
	Open instrument Settings window (Setup > Edit)	Configure instrument settings. See page 3-9.
	Pause a test	Allows viewing or capture of results screens. ²
	Resume a test	
	Open the help window	Obtain NetTek YBT1 help.

¹ **BuiltInDisk\YBT1\Results.**

² **Data collection continues while screen is paused.**

Configuration Buttons

Select an option button for the type of circuit connection you want to make. For detailed information on connecting the NetTek YBT1 to a signal, see page 3-1.

 **Monitor.** Selecting Monitor provides a nominal 100 Ω input impedance and compensates for the 20 dB resistive loss of a DSX monitor port. This configuration is useful for in-service monitoring of T1 lines at DSX monitor ports that are resistor-isolated.

The YBT1 transmitter is disabled in Monitor configuration.

 **Bridge.** Selecting Bridge provides greater than 1 k Ω input impedance for bridging lines that are already terminated and compensates for cable losses of up to 10 dB.

The YBT1 transmitter is disabled in Bridge configuration.

 **Terminate.** Selecting Terminate provides a nominal 100 Ω input impedance and compensates for up to 10 dB of cable loss for T1 lines.

This configuration enables the NetTek YBT1 transmitter for error insertion, which is useful for out-of-service testing when you can terminate the line.

 **Loopback.** Selecting Loopback provides a nominal 100 Ω input impedance and compensates for up to 10 dB of cable loss in T1 lines.

Use this configuration to take measurements on received data while looping the payload data from the receiver back to the transmitter. Loopback is useful when testing from the far end of a T1 line.

 **Loop Far End.** Selecting the Loop Up button initiates transmission of the loop code specified in the Settings Dialog Box Loop Codes tab (Setup > Edit > Loop Codes). This configuration is the result of the NetTek YBT1 sending a loop code and successfully completing a loop back of equipment at the far end. For additional information, see *Loop Codes Button* on page 2-13.

NetTek YBT1 test functionality using a far end loop is identical to that of Terminate configuration.

Select the **Loop Down** button to remove the far end loop and return the NetTek YBT1 to Terminate configuration.

NOTE. *You must use Terminate configuration to activate the Loop Up button.*

Loop Codes Button

Select this button to open the Settings Dialog Box Loop Codes tab (Setup > Edit > Loop Codes). Use this dialog box to setup a loop code.

The ANSI T1 standard defines the following loop control formats:

- **In-Band Codes:** transmitted in place of payload data (without framing bits). These codes are repeated continuously for a period of 5 seconds and are defined for use with either D4 (Superframe) or ESF framing formats.
- **Out-of-Band Codes:** defined for ESF framing only. An out-of-band communication link does not exist for D4 framing.

Additionally, there are two types of loop codes:

- **Line Loopback:** generates a full 1.5444 Mbps stream looping back from the receiver to the transmitter, including the framing bits.
- **Payload Loopback:** the equipment performing the loopback generates the framing, looping back 1.536 Mbps user channel data only.

The YBT1 Tester uses line loopback codes only.

1. Select the appropriate option button to specify a loop code:
 - **CSU:** select a loop code in the drop-down menu.
 - **NIU:** select a loop code in the drop-down menu.
 - **User:** tap the keypad icon to open the numeric keypad; then tap the left and right arrows to enter a binary code.
2. Tap **OK**.

The current loop code is displayed below the Loop Up / Loop Down button.

Loop Up Button 

Select this button to send a loop code and loop up equipment at the far end. For additional information, see *Loop Far End* on page 2-12.

The current loop code is displayed below the Loop Up / Loop Down button.

Loop Down Button 

Select this button to remove the far end loop and return the NetTek YBT1 to Terminate configuration. For additional information, see *Loop Far End* on page 2-12.

Tx Setup Button 

Select this button to open the Settings Dialog Box Instrument tab (Setup > Edit > Instrument) and configure the NetTek YBT1 transmitter test parameters.

1. Select from the option buttons to configure the Line Coding, Framing, and Transmit Clock settings.
2. Select from the option buttons to set the Transmit Level (output) for a Terminate test configuration.
3. Select a Bit Error Rate (BER) test pattern from the drop-down list box.
4. Tap **OK**.

The settings you enter become the active settings. They also are used as the default settings at the next power up. The current NetTek YBT1 transmitter settings are displayed below the Tx Setup button.

NOTE. *Changing the test parameters automatically restarts the alarm and error counters.*

Restart Button 

Select this button to reset all of the current measurement status and history, including error and alarm counts. If any instrument setting is configured for “Same as Rx Signal”, a Restart will initiate the receiver detection algorithm for the selected setting(s).

Rx Level Button 

The NetTek YBT1 continuously monitors the received signal level strength. Select this button to open the Receive Level window and display the signal level strength in dBdsx and Volts peak-to-peak.

Line Code Button 

The NetTek YBT1 continuously monitors the received signal to determine the line coding. Select this button to open the Line Code Detect window and display the line code currently being received.

The History field displays the number of seconds the indicated line code has been received since the measurement began.

NOTE. *The Line coding setting in the Setup > Edit > Instrument tab must match the line code of the signal you are testing. You may need to manually set the Line coding before taking measurements.*

NOTE. *Some received data patterns do not allow accurate detection of line coding. In such cases, the NetTek YBT1 will report AMI line coding. For meaningful detection to occur, the received data must have sufficiently low ones density (or long enough strings of zeros) to induce B8ZS substitutions.*

Drop DS0 Button 

Select this button to open the DS0 Activity Graph. This view displays the data activity for each of the T1 time slots. Activity is indicated as percentage ones-density in each time slot, represented as

a unique color ranging from all zeros through all ones in 10% increments.

Each row of the display represents a user-defined period of time. Over multiple time periods, the display builds up row-by-row with the oldest row dropping from the top of the view as the newest row is added to the bottom.

To monitor audio data on a selected channel, do the following:

1. Tap the DS0 channel at the bottom of the display, 1 through 24.
2. Set the the speaker option button to on.
3. Tap and drag the slider to control the speaker volume.

Timed Test Button

Select this button to open open the Timed Test window. Use this window to define the length of time to run a controlled test.

Auto Test Button

Select this button to open the Bert Pattern Selection dialog box. Use this dialog box to select and run a preset or custom BER test pattern sequence. See page 3-15 for additional information.

Open Last Results

If you accidentally pressed Restart or lost data while updating the display time span, select **File > Open Last Results**. This command returns the results of the previous test, or data collected since the last Restart. You can use most of the controls to analyze the logged data.

NOTE. *If you accidentally lost data by selecting the wrong control, select **File > Open Last Results** to return the results of the previous test.*

Summary Tab

Select this tab to open the Summary window. See page 2-19 for detailed information.

Alarms Tab Alarms

Select this tab to open the Alarms window. See page 2-20 for detailed information.

Errors Tab Errors

Select this tab to open the Errors window. See page 2-23 for detailed information.

History Tab History

Select this tab to open the Test History window. See page 2-26 for detailed information.

Rx Status Indicator

This indicator identifies valid T1 pulses at the NetTek YBT1 Receive input.

- Green indicates that T1 pulses have been detected.
- White indicates that the NetTek YBT1 is searching for T1 pulses.

During the search the T1 pulse indicator displays *Receiving*. If the NetTek YBT1 detects T1 pulses at a level too low to make accurate measurements, it displays *Weak Signal* and continues searching.

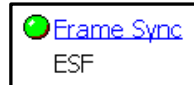
Frame Sync Indicator

The NetTek YBT1 compares the data framing detected at the Receive input to the criteria selected in the Settings Dialog Box Instrument tab (Setup > Edit > Instrument).

- Green indicates that the received framing matches the instrument settings.
- Red indicates that the received framing does not match the instrument settings.
- White indicates that the NetTek YBT1 is searching for framing synchronization.

The Frame Sync Indicator displays the type of framing detected: *D4* or *ESF*. During the search the indicator displays *Receiving*.

Pattern Sync Indicator



The NetTek YBT1 compares the data pattern at the Receive input to the BER pattern selected in the Settings Dialog Box Instrument tab (Setup > Edit > Instrument).

- Green indicates that the received data pattern matches the instrument settings.
- Red indicates that the received data pattern does not match the instrument settings.
- White indicates that the NetTek YBT1 is searching for pattern synchronization.

The Pattern Sync Indicator displays the type of pattern detected if known: *QRSS*, *ALL Ones*, *All Zeros*, *1 in 8...* During the search the indicator displays *Receiving*.

If a known pattern is not detected for a period exceeding 10 seconds, the indicator displays *Unknown*. Unknown is also a likely pattern detected for live lines.

Instrument Settings

For information on how to modify the NetTek YBT1 instrument settings, such as line coding, framing, transmitter clock, BER test patterns, and transmitter output level, or how to perform specialized testing on T1 circuits, see page 3-9.

Understanding the Summary Window

This is the default test window. The Summary window reports the accumulated test results since the last time you began a test or selected the Restart button. View this window to obtain general information before navigating to other windows for detailed results.

To open this window, select the **Summary** tab on the left side of the display.

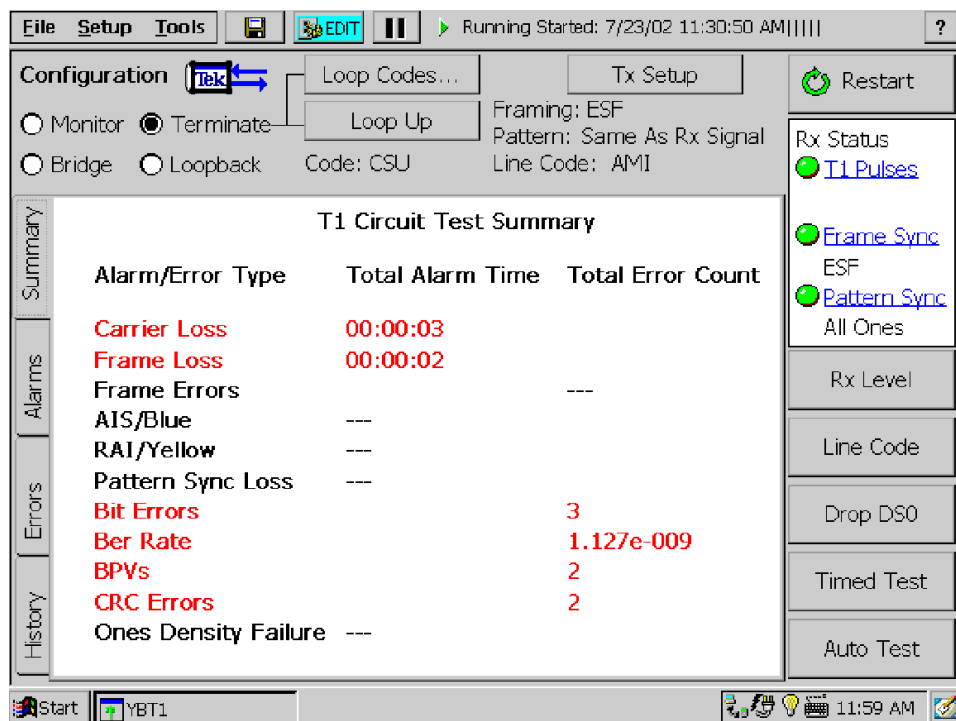

Figure 2-5: NetTek YBT1 Summary window

T1 Circuit Test Summary

This field summarizes the current test results.

OK. Indicates that no alarms or errors were detected during the test period or since the last Restart.

Alarm /Error Type. Lists the type of alarm or error detected during the test period.

Total Alarm Time. Lists the time duration of the alarm.

Total Error Count. Lists details specific to the detected error(s).

Understanding the Alarms Window

This window reports alarm events collected during the test period. View this window to obtain alarms event history from the Alarms Rolling Display. To open to this window, select the **Alarms** tab on the left side of the display.

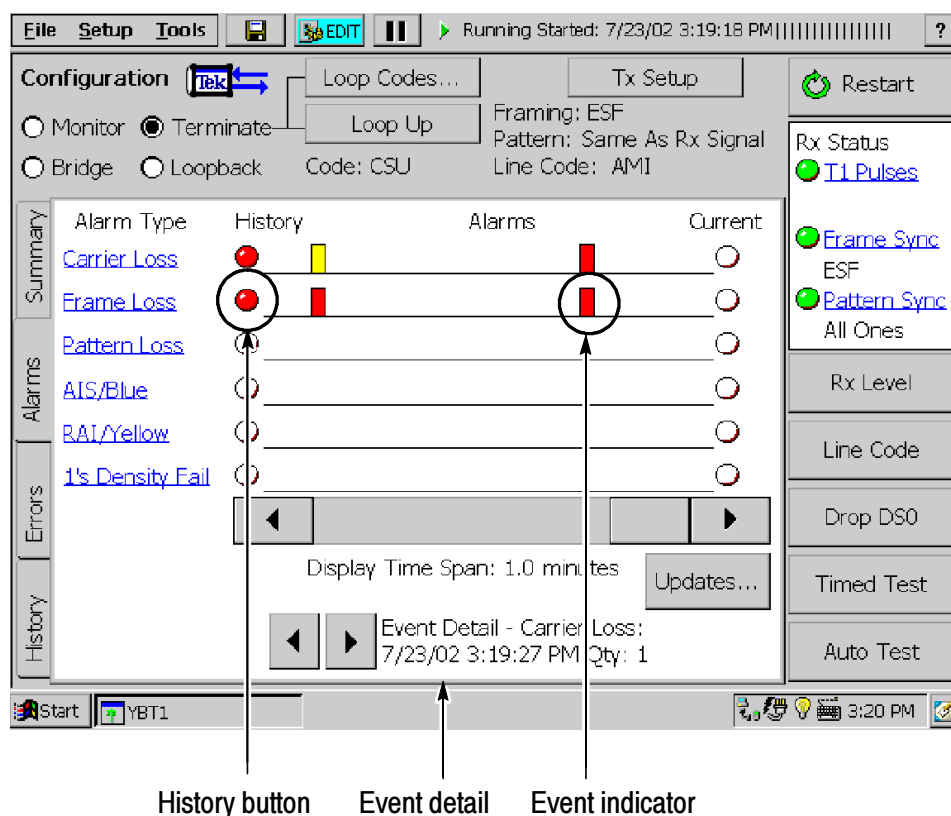

Figure 2-6: NetTek YBT1 Alarms window

Alarms Rolling Display

The Alarms Rolling Display scrolls from right to left to document alarm events in time.

Event Indicator

An event indicator marks the occurrence of an alarm event. Each indicator represents the time period specified by the data collection resolution.

To view details of an event, tap on an event indicator. The indicator changes color from red to yellow following your tap. Details of the event appear in the Event Detail field at the bottom of the display.

History Indicator

On the left side of the rolling display, a red History indicator denotes that historical information is available for the alarm type indicated; a white history indicator denotes that no historical information is available.

Select the History tab to view accumulated alarm details for the last 150 time intervals or the number of alarms detected since the beginning of the test.

Current Indicator

Red indicates this alarm type is currently being detected; white indicates that this alarm type is not being detected.

Display Time Span

To set the collection resolution and data collection time of the Alarms Rolling Display, do the following:

1. Tap the **Updates** button in the Alarms window (Setup > Edit > Data Collection).
2. Select a Time Interval (data collection time) from the drop-down list box.
3. Tap **OK**.

The 30 most recent time intervals comprise the default display time span of the rolling display. You can scroll beyond the 30 most recent events by tapping and dragging the scroll bar. Select the History tab

to review details of the last 150 time intervals or the number of errors detected since the beginning of the test.

Updated settings become the active settings. They will also be used as the default settings at the next power up.

NOTE. *Updating the time interval restarts the test. Data collected for the current test is deleted from memory.*

Event Detail

Tap on an event indicator in the rolling display to list the time, date, and number of alarms detected within the time interval represented by the selected event indicator. Information is displayed in the Event Detail field at the bottom of the window.

Tap the left and right arrows to scroll through the time record for information on each event.

Understanding the Errors Window

This window reports error events collected during the test period. View this window to obtain errors event history from the Errors Rolling Display. To open this window, select the **Errors** tab on the left side of the display.

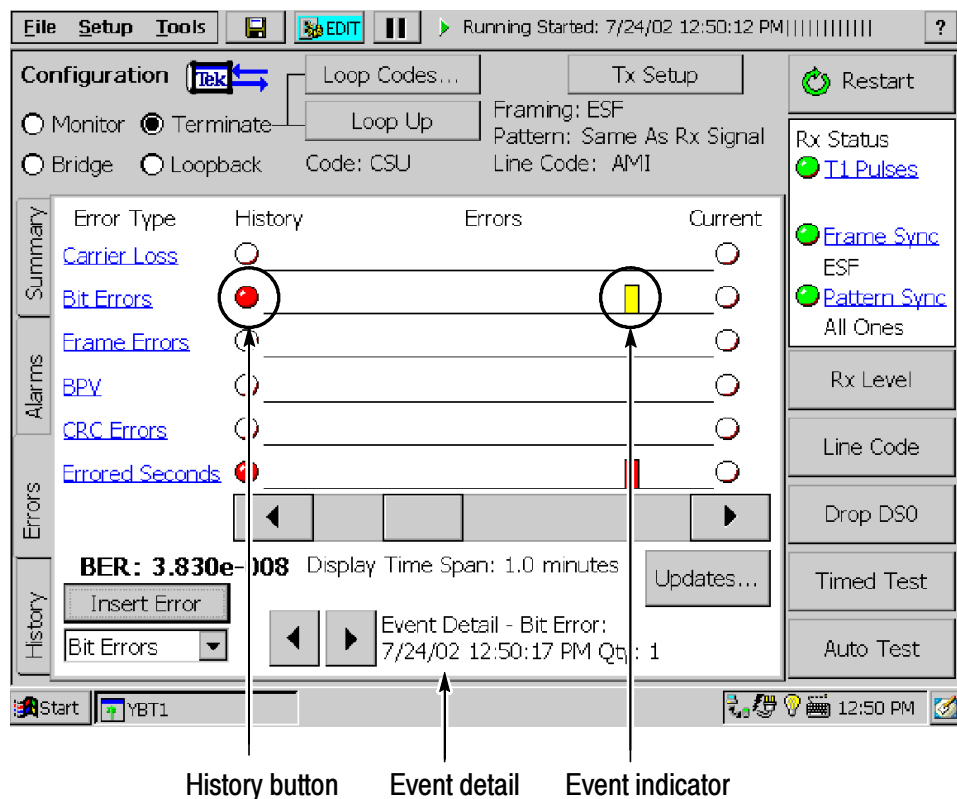

Figure 2-7: NetTek YBT1 Errors window

Errors Rolling Display

The Errors Rolling Display scrolls from right to left to document error events in time.

Event Indicator

An event indicator marks the occurrence of an error event. Each indicator represents the time period specified by the data collection resolution.

To view details of an event, tap on an event indicator. The indicator changes color from red to yellow following your tap. Details of the event appear in the Event Detail field at the bottom of the display.

History Indicator

On the left side of the rolling display, a red History indicator denotes that historical information is available for the error type indicated; a white history indicator denotes that no historical information is available.

Select the History tab to view accumulated error details for the last 150 time intervals or the number of alarms detected since the beginning of the test.

Current Indicator

Red indicates that this Error Type is currently being detected.

Display Timespan

To set the collection resolution and data collection time of the Errors Rolling Display, do the following:

1. Tap the **Updates** button in the Errors window (Setup > Edit > Data Collection).
2. Select a Time Interval (data collection time) from the drop-down list box.
3. Tap **OK**.

The 30 most recent time intervals comprise the default display time span of the rolling display. You can scroll beyond the 30 most recent events by tapping and dragging the scroll bar. Select the History tab to review details of the last 150 time intervals or the number of errors detected since the beginning of the test.

Updated settings become the active settings. They will also be used as the default settings at the next power up.

NOTE. *Updating the time interval restarts the test. Data collected for the current test is deleted from memory.*

Event Detail

Tap on an event indicator in the rolling display to list the time, date, and number of alarms detected within the time interval represented by the selected event indicator. Information is displayed in the Event Detail field at the bottom of the window.

Tap the left and right arrows to scroll through the time record for information on each event.

BER Count

The BER: indicator (bit error rate indicator) displays the cumulative bit error rate since the last time you began a test or selected the Restart button. The reported BER is calculated for the total number of bits received for a synchronized pattern session.

Error Insertion List Box

To insert a single error into the NetTek YBT1 output data stream:

1. Configure the NetTek YBT1 for a Terminate connection. See page 3-4 for instructions.
2. Select an error type from the Insert Error drop-down list box.
3. Tap the **Insert Error** button.

The NetTek YBT1 transmits a single error immediately. You must loop the far end connection to monitor errors at the Rx (Receive) input of the NetTek YBT1. See *Loop Far End* on page 2-12 for further details.

Understanding the History Window

The History window lists test results since the last time you began a test or selected the Restart button.

View this window for detailed information on the last 150 alarms and errors, including the alarm/error type, number of occurrences (count), and the time of each occurrence.

You can sort the information in this window by alarms/errors type, count (in descending order), and time of occurrence by tapping the appropriate column header.

To open this window, select the **History** tab on the left side of the display.

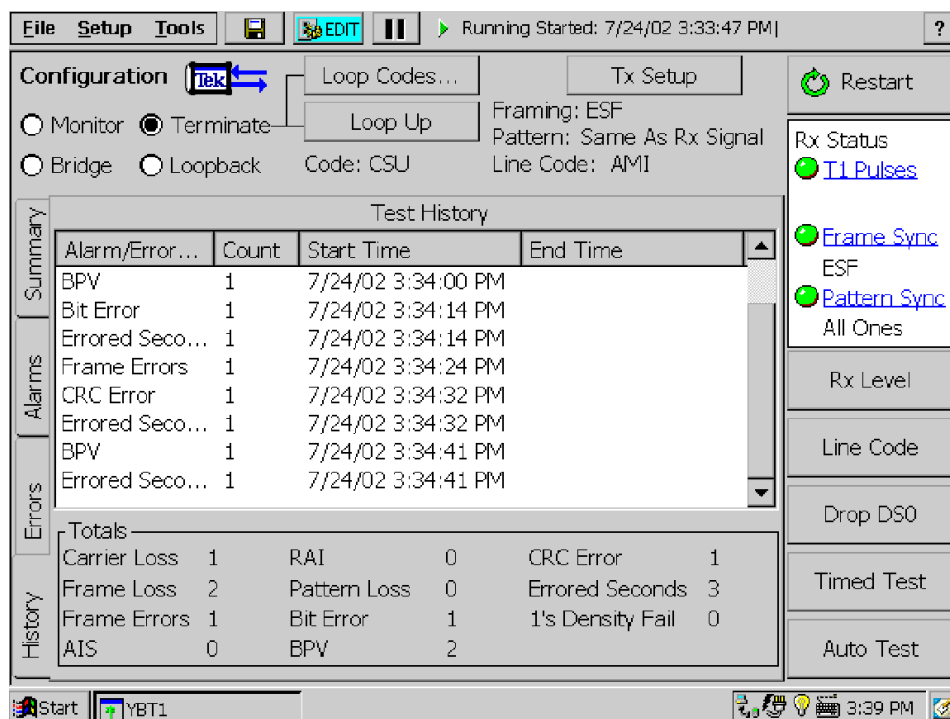

Figure 2-8: NetTek YBT1 History window



Reference

Connecting to a Signal

There are several ways to connect the NetTek YBT1 to a T1 circuit within the base station environment. Each type of connection allows you to test a different aspect of functionality.

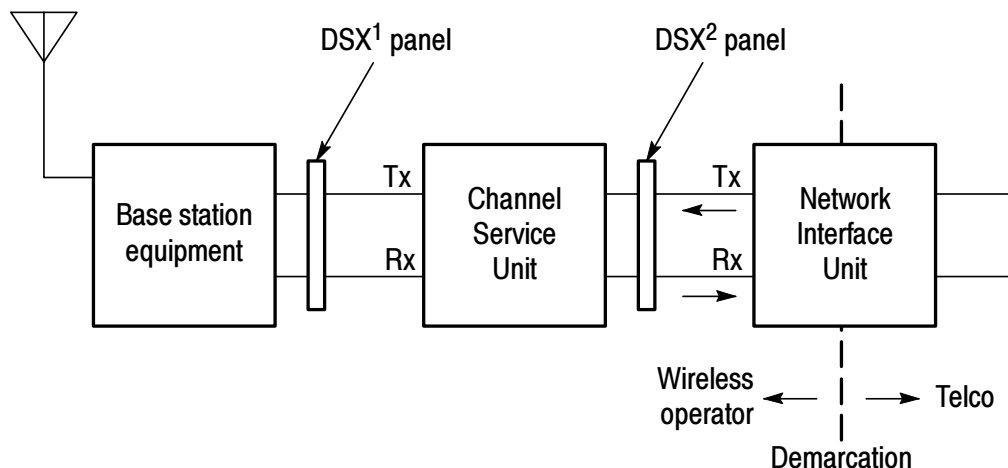

Figure 3-1: Typical base station showing T1 network interfaces

Making a Monitor Connection

This is the most common type of connection to a DSX service panel. With this configuration, you can use the YBT1 to monitor either the network side or the customer side of the data stream, without removing the line from service. This configuration does not transmit data, therefore it does not block communications on either side.

Use this configuration to detect errors on the line, such as Bipolar Violations (BPV) and CRC (Cyclic Redundancy Check) errors, or to perform bit error-rate testing if a known test pattern is being received.

As a typical example, to monitor an outgoing signal at a DSX service panel, configure the NetTek YBT1 as follows:

1. Connect the RJ48-to-Bantam Y Cable to the T1 Line Interface. See page 1-5.
2. Select the **Monitor** option button in the NetTek YBT1 Configuration field.
3. Connect the Bantam “Receive” plug to the monitor jack on the DSX¹ service panel as shown in Figure 3-2.
4. Select the **Summary** tab on the NetTek YBT1.
5. Press **Restart** to clear any alarm/error counts and begin the test.

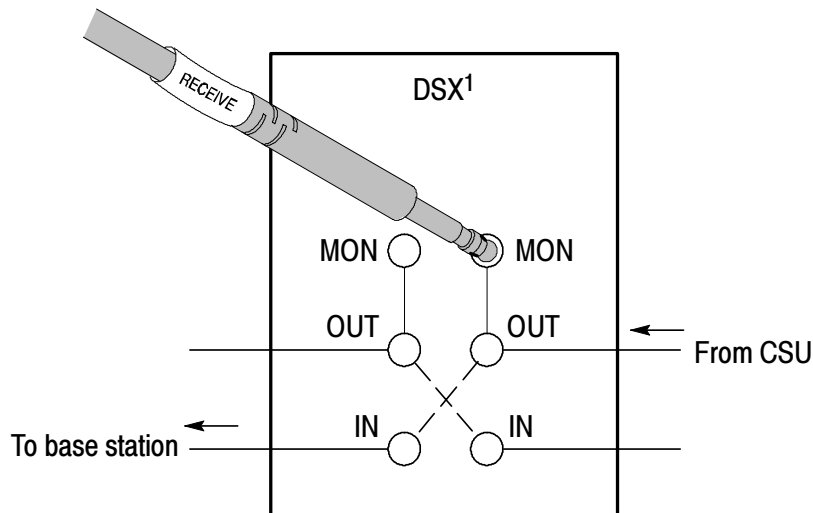

Figure 3-2: Typical connection for single-port monitoring

Making a Bridge Connection

Use this type of connection to perform nonintrusive testing on a T1 circuit, without being limited to a designated monitoring port with the appropriate isolation.

Use this configuration to detect errors online, such as bipolar violations and CRC errors, or to perform bit error-rate testing if a known test pattern is being received.

For example, to connect the NetTek YBT1 to a T1 circuit without loading the circuit, do the following:

1. Connect the RJ48-to-Alligator Clip Cable to the T1 Line Interface. See page 1-5.
2. Select the **Bridge** option button in the NetTek YBT1 Configuration field.
3. Connect the “Receive” alligator clips to the appropriate points in the service access. See Figure 3-3.
4. Select the **Summary** tab on the NetTek YBT1.
5. Press **Restart** to clear any alarm/error counts and begin the test.

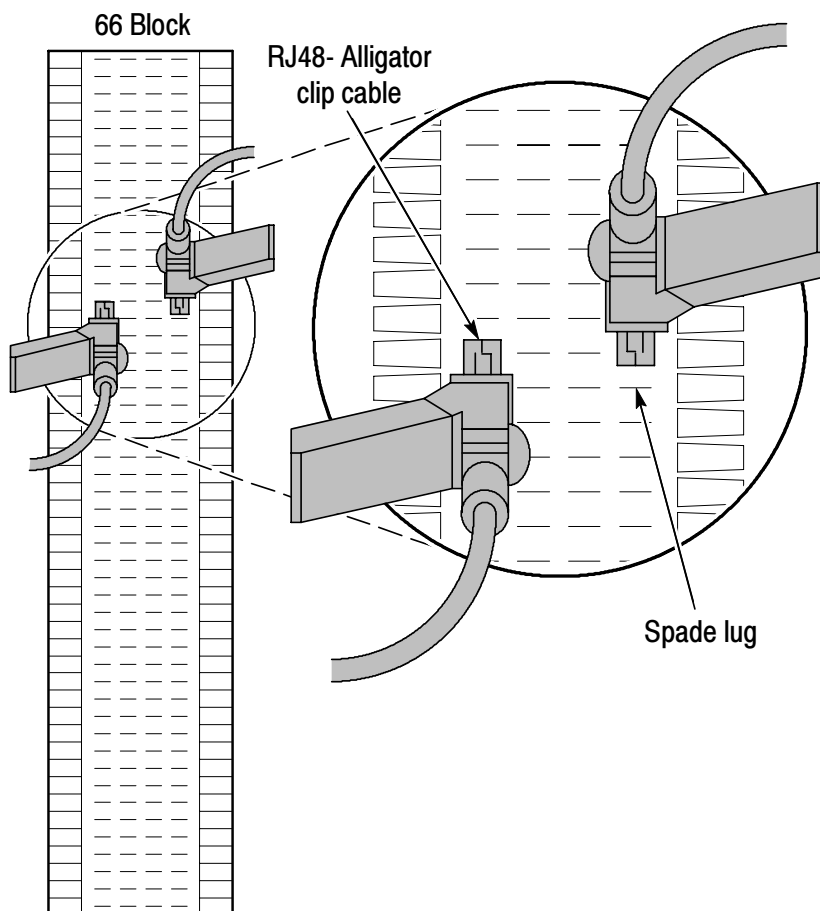

Figure 3-3: Typical connections for bridge monitoring

Making a Terminate Connection

Use this type of connection to place the NetTek YBT1 at the end of a service line when the line is out of service. With this configuration you can test base station equipment independent of the service line, or the service line independent of the base station.

For example, to test CSU equipment off line, connect the NetTek YBT1 as follows:

1. Connect the RJ48-to-Bantam Y to the T1 Line Interface. See page 1-5.

2. Select the **Terminate** option button in the NetTek YBT1 Configuration field.
3. Connect the “Transmit” Bantam plug to the IN side of the service access as shown in Figure 3-4.
4. Connect the “Receive” Bantam plug to the OUT side of the service access as shown in Figure 3-4.
5. Loop the DSX² service panel at the NIU.
6. Select the **Summary** tab on the NetTek YBT1.
7. Press **Restart** to clear any alarm/error counts and begin the test.

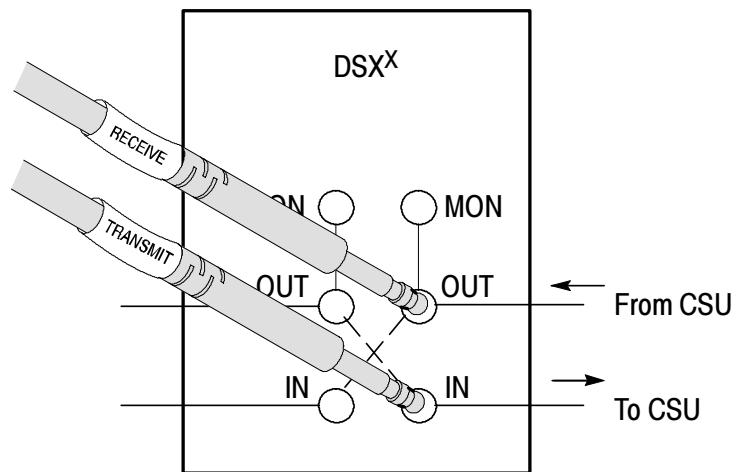

Figure 3-4: Typical connections for terminating a T1 circuit

Making a Loopback Connection

Use this type of connection to retransmit the incoming signal back to the point of origin through the NetTek YBT1. Looping back is virtually equivalent to hard wiring the receive side of the line to the transmit side of the line while allowing the NetTek YBT1 to make measurements on the received data.

For example, to loopback a T1 circuit through the NetTek YBT1, do the following:

1. Connect the RJ48-to-Bantam Y or RJ48-to-Alligator Clip Cable to the T1 Line Interface. See page 1-5.
2. Select the **Loopback** option button in the NetTek YBT1 Configuration field.
3. Connect the “Transmit” Bantam plug or alligator clips to the IN or OUT side of the service access, depending on the circuit you want to terminate. Connect the “Receive” Bantam plug or alligator clips to the other side of the line for monitoring purposes. See Figure 3-5.
4. Select the **Summary** tab on the NetTek YBT1.
5. Press the **Restart** button to clear any previous alarm/error counts and begin the test.

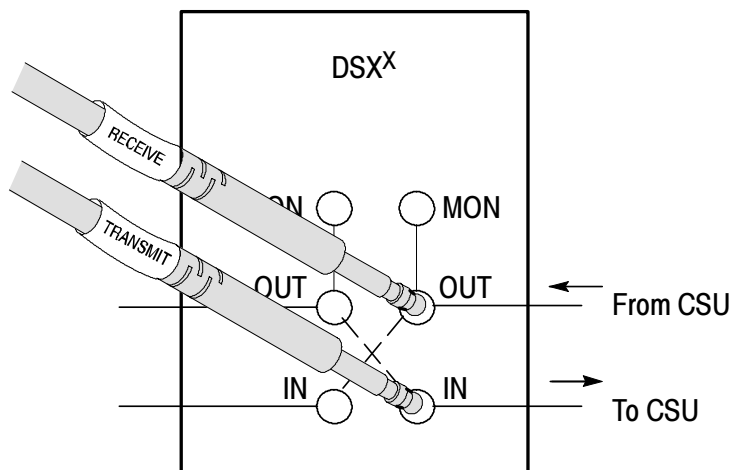

Figure 3-5: Typical connections for loopback mode

Testing a Circuit

After you connect the NetTek YBT1 to a signal, select the **Restart** button to begin testing. To assure accurate measurements, verify that there is sufficient receive signal level and that the line coding is correct:

1. Select the **Rx Level** button on the right side of the display. Verify that the signal level meets the minimum receiver sensitivity requirements listed in the Specifications section. See page A-1.
2. Select the **Line Code** button on the right side of the display. Verify that the expected line code is correct for the type of signal you are testing. For information on how to set the line code, see *Selecting Settings* beginning on page 3-9.

Typically, the first thing you see in the main window (Summary tab) is an indication that either the data stream contains no anomalies (the display reads “OK”), or that the NetTek YBT1 detected an alarm or error, in which case the T1 Circuit Test Summary results are displayed. The T1 Circuit Test Summary lists all of the alarms or errors detected since the last restart. See Figure 3-6.

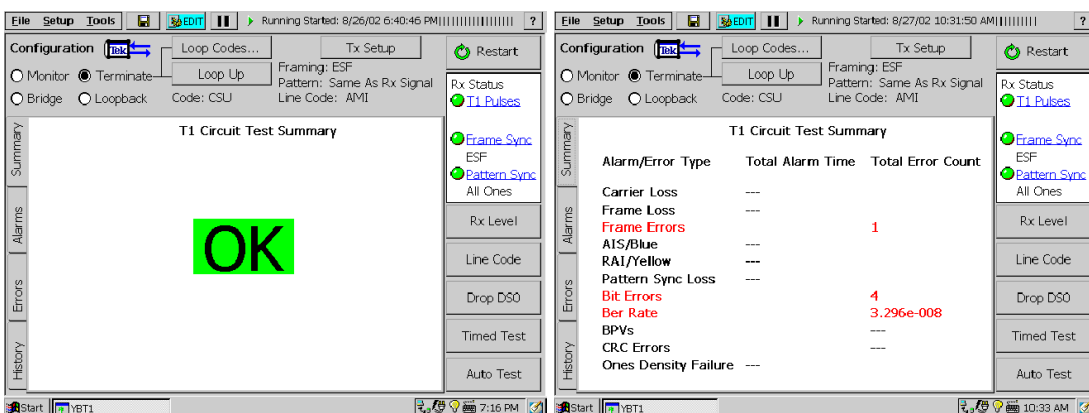

Figure 3-6: Summary window showing typical test results

If the NetTek YBT1 detected an alarm or error, open an Alarms or Errors window to obtain additional information. (To open a window select an Errors or Alarms tab.) These windows provide graphical presentations of the most recent test events, as well as indicators that show the current and past performance of the T1 line under test. To view an itemized list of the alarm or error history since the last restart, open the History tab.

You can also view all of the DS0 time slots simultaneously on the Drop DS0 activity graph. A colored bar is displayed for each consecutive time interval within the measurement time span. The display is color coded to reveal common data problem patterns:

- Normally quiet channels may be disrupted by random noise.
- Channels normally containing variable data may be locked into a continuous pattern.
- Normal startup protocol, represented by identifiable fixed bars, may not change to a variable pattern.

You can also use the Drop DS0 feature for aural identification of some signal problems. For additional information, see page 3-13.

To view the DS0 Activity Graph, select the **Drop DS0** button.

Measurement results accumulate as long as the NetTek YBT1 detects T1 pulses. You can view test summary results at the end of a timed test or while a test is running by selecting the History tab.

NOTE. *To ensure accurate measurements, always press the **Restart** button after you connect the NetTek YBT1 Tester to a circuit.*

Selecting Settings

The NetTek YBT1 automatically detects most of the parameters necessary to test a T1 circuit. However, you can override any or all of the automated settings to speed up synchronization or to perform specialized tests.

NOTE. *The Line Coding setting in the Setup > Edit > Instrument tab must match the line code of the signal you are testing. Select the **Line Code** button on the right side of the display to view the line code currently being detected. You may need to manually set the Line Coding in the Instrument tab before taking measurements.*

To set the NetTek YBT1 receive function for automated testing, do the following:

1. Select **Setup > Edit** in the toolbar at the top of the startup window.
2. Open the Instrument tab and configure the option buttons as follows:
 - a. Line Coding: **AMI** or **B8ZS**.
 - b. Framing: **Same as Rx Signal**.
 - c. Transmit Clock: **Recovered**.
 - d. Generated BER Pattern: **Same as Rx Signal**.

The NetTek YBT1 will automatically detect data formatting and analyze the received signal. To view summarized test results, tap the **Summary** tab and check the T1 Circuit Test Summary report. To view details of specific test results, select the **Alarms** or **Errors** tabs.

Instrument Settings Window

The Instrument Settings dialog box allows you to configure the NetTek YBT1 for specialized testing of T1 circuits.

1. Select **Setup > Edit** to open the dialog box; then open the Instrument tab. See Figure 3-7.

2. Select the option buttons appropriate to the tests you want to make.

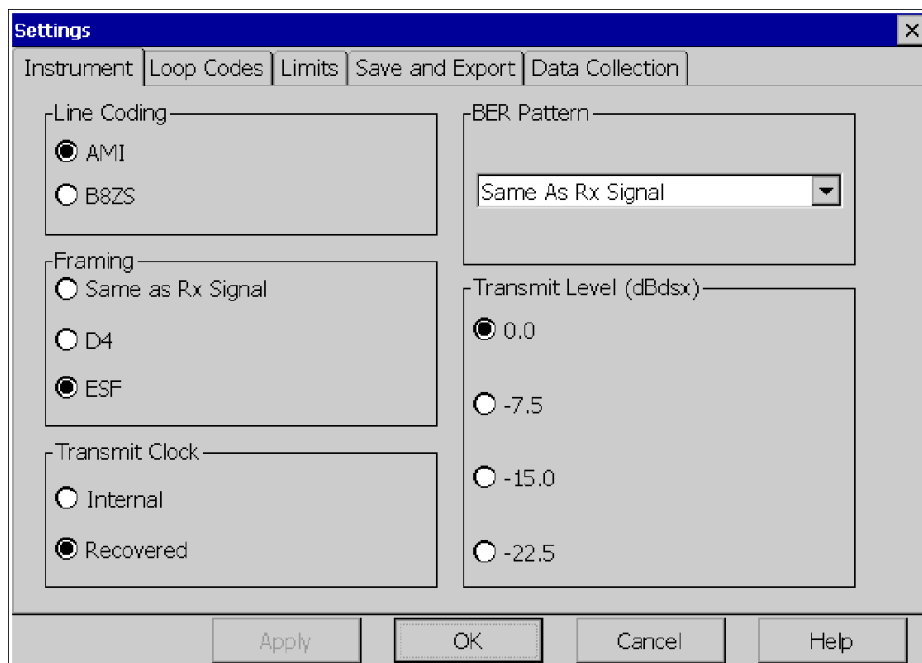

Figure 3-7: Instrument settings dialog box

Line Coding. Select the line coding for the YBT1 transmitter and receiver.

- **AMI.** The YBT1 receiver will not perform B8ZS decoding on incoming data.
- **B8ZS.** The YBT1 receiver will perform B8ZS decoding on incoming data.

Framing. Select the frame format of the YBT1 transmitter and receiver.

- **Same as Rx Signal.** Automatically detects the incoming framing format and configures the YBT1 receiver and transmitter to match.

- D4. Configures the YBT1 to transmit and receive T1 data with D4 (SuperFrame) framing.
- ESF. Configures the YBT1 to transmit and receive T1 data with ESF (Extended SuperFrame) framing.

Transmit Clock. Select the YBT1 transmitter timing reference.

- Internal. Configures the YBT1 transmitter to use the internal crystal oscillator as a reference. See *Appendix A: Specifications* for frequency information.
- Recovered. Configures the YBT1 transmitter to use the clock recovered from the received data as a reference.

BER Pattern. Select the YBT1 transmitter and receiver Bit Error Rate test pattern from the drop-down list box.

- Same as Rx. The YBT1 automatically detects the incoming pattern and configures the receiver to match. Following synchronization, the transmitter is configured to transmit the same pattern.
- QRSS. Simulates voice signals of approximately 50% ones density. Best used to stress metallic circuits.
- All Ones. Simulates maximum power delivery conditions. Best used to stress repeated spans.
- All Zeros. Use in conjunction with B8ZS coding to force bipolar variations in equipment improperly configured for AMI line coding.
- 1 in 8. Uses minimum ones density to stress the clock recovery of receivers and repeaters.
- 2 in 8
- 3 in 24. Uses minimum ones density with maximum zeros to stress clock recovery.
- T1-1 (Min/Max)
- T1-2 (Trip Test)
- T1-3 (54 Octet)

- T1-4 (120 Octet)
- T1-5 (53 Octet)
- T1-6 (55 Octet). Provides a rapid transition from low to high ones density without aligning to the frame boundaries. Best used for acceptance testing.
- User Defined. Create and edit your own BER pattern. All patterns are defined in 8-bit octets.

Transmit Level (dBdsx). Select the power level and pulse shape for the YBT1 transmitter. You can adjust the settings to simulate the insertion of varying lengths of twisted-pair cable. For example, 0 dBdsx corresponds to a “nominal” signal level of 3 V peak.

- 0.0
- -7.5
- -15.0
- -22.5

Select **Apply** to configure the YBT1 for the selected settings and initiate a restart. The Settings window will remain open.

Select **OK** to configure the YBT1 for the selected settings and initiate a restart. The Settings window will close and the measurement window will return.

Select **Cancel** to return the original settings and cancel your selections. The measurement window will return.

Setting the Alarms and Errors Rolling Display Data Collection Resolution

You can set the data collection resolution and data collection time of the Alarms and Errors rolling displays by selecting a value in the Updates > Time Interval (Data Collection Time) drop-down list box.

1. Select the **Alarms** or **Errors** tab; then select **Updates**.
2. Select a Time Interval (data collection time) from the drop-down list box.

3. Tap **OK**.

This value specifies the data collection period represented by each event indicator in the rolling display. A maximum of 150 time intervals is allowed before the display memory allocation is exceeded and previously collected data is overwritten. The Data Collection Time = Time Interval x 150.

The Display Time Span of the rolling display is also defined by the data collection resolution, consisting of the most recent 30 time intervals.

You can scroll beyond the 30 most recent time intervals and access historical data by tapping and dragging the display scroll bar, which is located just above the Updates button.

To review the details of the last 150 time intervals (or the number of errors detected since the beginning of the test) in table format, select the History tab.

NOTE. *Updating the time interval restarts the test. Data collected for the current test is deleted from memory.*

Updated settings become the active settings. They will also be used as the default settings at the next power up.

Using the DS0 View

Select the **Drop DS0** button on the right side of display to open the DS0 view.

The DS0 view displays the data activity for each of the T1 time slots. Activity is indicated as percentage of ones-density in the time slot, represented as a unique color for ones-density categories ranging from all zeros through all ones in 10% increments.

Each row of the display represents a user-defined period of time. Over multiple time periods, the display builds up row by row, with the oldest row being dropped off the top as the new row is added to the bottom.

This display can be useful in detecting DS0 muxing problems, identifying PRI control channels, or identifying concatenated DS0 data "pipelines" configured on the T1 circuit under test.

To change the update interval of the Data Record display:

1. Select the **Updates** button.
2. Set the data collection update interval as explained in *Setting the DS0 Data Collection Update Time Interval* below.

NOTE. *Errors and alarms data collection continues while viewing this screen. To view the Errors or Alarms count, select the **Close** button; then select the desired display tab.*

Setting the DS0 Data Collection Update Time Interval

To set the update interval of the DS0 Activity Graph data record, do the following:

1. Select **Setup > Edit > Data Collection**.
2. Select a Minutes, Hours, or Days option button.
3. Tap the corresponding left/right arrows to increment or decrement the Update Interval value. (You can also tap the keyboard icon in the taskbar or attach an external PS2 keyboard to enter a specific value.) The DS0 Activity Graph time span (data record full screen) is shown in the scroll box.
4. Tap **OK**.

NOTE. *The updated settings become the active settings. They will also be used as the default settings at the next power up.*

Updating the time interval restarts the test. Data collected for the current test is deleted from memory.

Monitoring Audio Data On a DS0 Channel

Use the following procedure to monitor audio data on a selected DS0 channel:

1. Tap a DS0 channel at the bottom of the display, 1 through 24.
2. Set the the speaker option button to **On**.
3. Tap and drag the slider to control the speaker volume.

Performing an Automated Test

To run a series of preselected BER tests for specified periods of time, perform the following steps:

1. Select the **Auto Test** button on the right side of display.
2. Select a Pattern Sequence from the drop-down list box:
 - **Acceptance.ber.** Runs a standard sequence of BER patterns that you can use as an acceptance criteria for new T1 circuits.
 - **AMI Stress.ber.** Runs a sequence of BER patterns designed to stress equipment configured for AMI line coding.
 - **B8ZS Stress.ber.** Contains a sequence of BER patterns designed to stress equipment configured for B8ZS line coding.
3. Select **Create/Edit** to build you own custom test sequence. See *BERT Sequence Editor* on page 3-15 for information on how to use the editor.
4. Select **Start Test**.

The selected sequences run for the specified number of minutes. The NetTek YBT1 pauses at the end of the test and opens a Pattern Sequence Results window, similar to the one shown in Figure 3-8 on page 3-19.

BERT Sequence Editor

Select **Auto Test > Create/Edit**.

The Create/Edit a Pattern Sequence dialog box allows you to edit predefined test patterns to create your own custom test sequences. You may also create and name a new test pattern sequence using the controls in this dialog box.

For example, you could assemble the following Acceptance.ber test pattern sequence:

- Send all Ones for 15 minutes
- Send 1 in 8 for 30 minutes
- Send T1-6 (55 Octet) for 15 minutes
- Send 3 in 24 for 4 hours
- Send QRSS for 12 hours

Selected Pattern Sequence. This field lists the pattern you selected in the drop-down list box of the Bert Pattern Selection dialog box (after you selected the Auto Test button).

Pattern. This field contains a list of the available test patterns. To select a pattern, tap on the pattern name you wish to select.

Pattern Duration. This field contains a list of the common pattern durations. Select a time duration by tapping the desired setting. To create a custom time duration, select Other... and enter the time in hh:mm (hours:minutes) on the pop-up keypad.

Pattern Sequence. This field lists the details of the pattern you selected or are editing.

Save Sequence. You can save the sequence you have just edited/created by pressing this button. Note that you may not save a Pattern Sequence under the same name as the predefined pattern sequences, but you may rename the sequence using the dialog window that appears.

Save Sequence As. You can save the sequence you have just edited/created by selecting this button and typing in your new sequence name.

Cancel. Select this button to cancel and close the Create/Edit a Pattern Sequence dialog box.

To edit an existing pattern sequence, select a pattern in the Bert Pattern Selection drop-down list box; then select the **Create/Edit** button. In the Create/Edit a Pattern Sequence dialog box, you can customize the Pattern Sequence by selecting entries in the list boxes and using the Add or Remove buttons.

For example, to change the time duration of an individual pattern in an existing BERT pattern sequence, do the following:

1. Select the **Auto Test** button to open the Bert Pattern Selection dialog box.
2. Select the BERT pattern you want to modify in the drop-down list box.
3. Select **Create/Edit** to open the Create/Edit a Pattern Sequence dialog box.
4. Select the name of a pattern you want to modify in the Pattern list box.
5. Select a time duration in the Pattern Duration list box.
6. Select **Add** to insert the new pattern in the Pattern Sequence list box above the entry you want to replace.
7. Select the pattern you are replacing in the Pattern Sequence list box.
8. Select **Remove**.
9. Select **Save Sequence**.

You can create a custom pattern sequence by selecting **Remove All** and adding your own contents to the Pattern Sequence list:

1. Select the desired Pattern(s) and associated Pattern Duration in the list boxes.
2. Select **Add**.
3. Select **Save Sequence**.

NOTE. *To start an automated test, you must return to the BERT Pattern Selection dialog box.*

Pattern Sequence Results View

This window displays the results of the automated BER pattern sequence test; it automatically opens when the sequence is completed.

Results are displayed in table format, with each row representing one of the test patterns employed in the test. See Figure 3-8 on page 3-19.

- **Pattern.** The BER test pattern used in this section of the test.
- **Duration.** The programmed duration for the transmission of this test pattern. The format is hh:mm.
- **Pattern Availability.** The actual time duration in which the pattern was received. The format for this column is hh:mm:ss. If the NetTek YBT1 lost pattern synchronization or framing for any period during the programmed pattern duration, this number will be minus the Duration. The time required to obtain pattern synchronization with the incoming pattern may also cause the Pattern Availability to be less than the programmed duration.
- **Bit Errors.** The bit error count for this pattern.
- **Bit Error Rate.** The bit error count divided by the number of received bits during the Pattern Availability duration.
- **BPV.** The number of BiPolar Violations received during the pattern duration.
- **CRCs.** The number of CRC Errors received during the pattern duration.
- **Frame Errors.** The number of Frame Errors received during the pattern duration.

Select **Run Again** to repeat the test.

Pattern	Duration	Pattern...	Bit Errors	Bit Error Rate	BPVs	CRCs	Frame ...
All Ones	00:01:00	00:01:00	0	0.000e+000	0	0	0
1 in 8	00:01:00	00:01:00	0	0.000e+000	0	0	0
3 in 24	00:01:00	00:01:00	0	0.000e+000	0	0	0
QRSS	00:01:00	00:01:00	0	0.000e+000	0	0	0
T1-6 (55...	00:01:00	00:01:00	0	0.000e+000	0	0	0

All time durations are in hh:mm:ss format.

Run Again Close Help

Start YBT1 Help 12:54 PM

Figure 3-8: Pattern sequence results window

Setting Up a Far End Loop

This test configuration is the result of the NetTek YBT1 sending a loop code and successfully completing a loop up of equipment at the far end. Selecting the Loop Up button initiates transmission of the loop code specified in the Setup > Edit > Loop Codes tab.

This configuration is similar to the Terminate configuration except that a far end loop has been established. Selecting the Loop Down button removes the far end loop and returns the NetTek YBT1 to Terminate configuration.

NOTE. You must set the NetTek YBT1 to Terminate configuration to use this feature.

Setting Up a Loop Code

1. Select **Setup > Edit > Loop Codes**.

The ANSI T1 standard defines the following loop control formats:

- **In-Band Codes:** transmitted in place of payload data (but not framing bits). These codes are repeated continuously for a period of 5 seconds and are defined for use with either D4 (Superframe) or ESF framing formats
- **Out-of-Band Codes:** defined for ESF framing only. An out-of-band communication link does not exist for D4 framing.

Additionally, there are two types of loop codes:

- **Line Loopback:** generates a full 1.5444 Mbps stream looping back from the receiver to the transmitter, including the framing bits.
 - **Payload Loopback:** the equipment performing the loopback generates the framing, looping back 1.536 Mbps user channel data only.
- #### 2. Select the appropriate option button to specify a loop code; the YBT1 Tester uses line loopback codes only:
- **CSU:** select a loop code in the drop-down list box.
 - **NIU:** select a loop code in the drop-down list box.
 - **User:** tap the keypad icon to open the numeric keypad; then tap the left and right arrows to enter a binary code.

3. Tap **OK**.

The current loop code is displayed below the Loop Up / Loop Down button.

NOTE. *The Loop Down button appears after you have selected the Loop Up button and successfully completed a loop up of the far end.*



Appendices

Appendix A: Specifications

This section lists the electrical, environmental, and physical specifications of the NetTek YBT1 T1 Circuit Tester. All specifications are guaranteed unless labeled “typical.” Typical specifications are provided for your convenience and are not guaranteed.

The electrical characteristics listed in Table A-1 apply to the NetTek YBT1 operating within the environmental conditions listed in Table A-3 on page A-3.

Table A-1: Electrical characteristics

Characteristic	Description
Transmitter (Tx) Characteristics	
Pulse Shape	Compatible with ANSI T1.102, 1993 and DS1, DSX-1 specifications, section 6.2.5 to 6.2.8 and 6.2.10.
Output Jitter	UI peak-to-peak: < 0.02% Compatible with PUB 62411.
Data Format, nominal	AMI, B8ZS
Frequency accuracy, nominal	± 50 ppm
Loopback Codes	CSU, NIU, User-defined, In-band, Out-of-band
Receiver (Rx) Characteristics	
Input Impedance, nominal	Bridge mode: > 1000 Ω Monitor mode: 100 Ω ± 1.0% Loopback mode: 100 Ω ± 1.0% Terminated mode: 100 Ω ± 1.0%
Sensitivity	Terminate mode: 0 to -10 dBx ^{1, 4} Bridge mode: 0 to -10 dBx ^{2, 4} Monitor mode: -20 to -30 dBx ^{3, 4}
Level Measurements	dBdsx ⁵ or V _{p-p}

Table A-1: Electrical characteristics (Cont.)

Characteristic	Description
Jitter Tolerance, nominal	400 to 100,000 Hz: complies with ITU, AT&T, and Telcordia requirements for T1 applications (PUB 62411, TRNWT 000499 Cat II, CCITT G.823, ITU-TI.431).
Jitter Transfer Curve, nominal ⁶	Attenuator meets the requirements of PUB 62411, PUB 43802, TR-TSY 009, TR-TSY 253, TR-TSY 499, and ITU-T1.431 and G.703.

¹ 100 Ω input impedance. Employs long-haul equalizer.

² 1 k Ω input impedance. Employs long-haul equalizer.

³ 100 Ω input impedance. Employs long-haul equalizer and 20 db amplification.

⁴ Rx Status Indicator (T1 pulses) reports *Weak Signal* when lower amplitude signals are detected.

⁵ ± 3 dB

⁶ NetTek Y350 reference clock.

Table A-2: Physical characteristics

Characteristic	Description
Dimensions ¹	Height: 25 cm (9.75 in) Width: 33 cm (13 in) Depth: 9 cm (3.5 in)
Weight ¹	One battery installed: 4.23 kg (9.2 lbs) Two batteries installed: 4.82 kg (10.2 lbs)

¹ Y350 NetTek Analyzer Platform with NetTek YBT1 PC card installed.

Table A-3: Environmental characteristics

Characteristic	Description
Temperature Range	
Operating	0 to +50 °C (+32 to +122 °F)
Nonoperating	-40 to +60 °C (-40 to +140 °F)
Humidity	
Operating	5 to 80% RH, noncondensing: 0 to +30 °C (14 to 86 °F) 5 to 30% RH, noncondensing: +30 to +50 °C (86 to 122 °F)
Nonoperating	5 to 80% RH, noncondensing: 0 to +30 °C (14 to 86 °F) 5 to 30% RH, noncondensing: +30 to +50 °C (86 to 122 °F)
Altitude	
Operating	4,600 m (15,333 ft)
Nonoperating	12,192 m (50,000 ft)

Table A-4: Certifications and compliances

Category	Standards or description
EC Declaration of Conformity - EMC	<p>Meets intent of Directive 89/336/EEC for Electromagnetic Compatibility. Compliance was demonstrated to the following specifications as listed in the Official Journal of the European Union:</p> <p>EN 61326 EMC requirements for Class A electrical equipment for measurement, control, and laboratory use.^{1,2,3}</p> <p>IEC 61000-4-2 Electrostatic discharge immunity (Performance criterion C).</p> <p>IEC 61000-4-3 RF electromagnetic field immunity (Performance criterion A).</p> <p>IEC 61000-4-4 Electrical fast transient / burst immunity (Performance criterion B).</p> <p>IEC 61000-4-5 Surge immunity (Performance criterion C).</p> <p>IEC 61000-4-6 Conducted RF immunity (Performance criterion A).</p> <p>IEC 61000-4-11 Voltage dips and interruptions immunity (Performance criterion B).</p> <p>EN 61000-3-2⁴ AC power line harmonic emissions.</p>
Australia/New Zealand Declaration of Conformity - EMC	<p>Complies with EMC provision of Radiocommunications Act per the following standard:</p> <p>AS/NZS 2064.1/2 Industrial, Scientific, and Medical Equipment:1992.</p>
FCC Compliance	<p>Emissions comply with FCC Code of Federal Regulations 47, Part 15, Subpart B, Class A Limits.</p>

Table A-4: Certifications and compliances (Cont.)

Category	Standards or description
U.S. Nationally Recognized Testing Laboratory Listing	UL 60950 3rd edition Safety of Information Technology Equipment.

- 1 **Emissions that exceed the levels required by this standard may occur when this equipment is connected to a test object.**
- 2 **Compliance demonstrated using high-quality, shielded interface cables.**
- 3 **Compliance demonstrated with NetTek YBT1 PC card installed in the rear PCMCIA slot of the Y350 NetTek Analyzer Platform.**
- 4 **(A14)**

Appendix B: Accessories

This section lists the NetTek YBT1 T1 Circuit Tester standard and optional accessories.

Standard Accessories

Table B-1 lists the accessories included with your tester.

Table B-1: Standard accessories

Quantity	Part number	Description
1 ea	015-0694-00	YBT1 PC Card
1 ea	119-6618-00	T1 Line Interface
1 ea	020-2424-00	Component kit: RJ48 loopback plug, single port RJ48-to-Bantam Y cable
1 ea	020-2427-02	NetTek YBT1 T1 Circuit Tester User manual. Includes software installation CD-ROM.

Optional Accessories

Table B-2 lists the optional accessories you can purchase for your YBT1 T1 Circuit Tester. Contact your Tektronix representative or distributor for ordering information. See page ix for information on contacting Tektronix.

Table B-2: Optional accessories

Part number	Description
020-2425-00	Component kit, contains 1 each: RJ48-to-RJ48 straight-wired cable, 6 ft RJ48-to-RJ48 cross-wired cable, 6 ft RJ48-to-Alligator clip cable, 6 ft

Appendix C: Diagnostic Self Tests

To verify the NetTek YBT1 T1 Circuit Tester is functioning properly, run the diagnostic self tests.

NOTE. *The following verification procedure does not confirm that the YBT1 T1 Circuit Tester meets or exceeds the specifications listed in Appendix A-1.*

1. Install the RJ48 Loopback Plug into the T1 Line Interface as shown in Figure 1-5 on page 1-10.
2. Power on the NetTek Analyzer Platform. See page 1-9 for instructions.
3. Select **File > Exit** in the YBT1 application if the T1 Circuit Tester is running.
4. In the taskbar, select **Start > Programs > Tektronix Utilities > Diagnostics**.
5. Tap the + box next to **All Modules, All Tests** to expand the selection tree.
6. Tap the + box next to **Platform**.
7. Deselect all platform diagnostics (remove all checks).
8. Tap the + box next to **Platform** again to compress the menu tree.
9. Tap the + box next to **YBT1**.
10. Verify that General Tests, Line Port Tests, and Monitor Dongle Tests are checked. See Figure C-1.

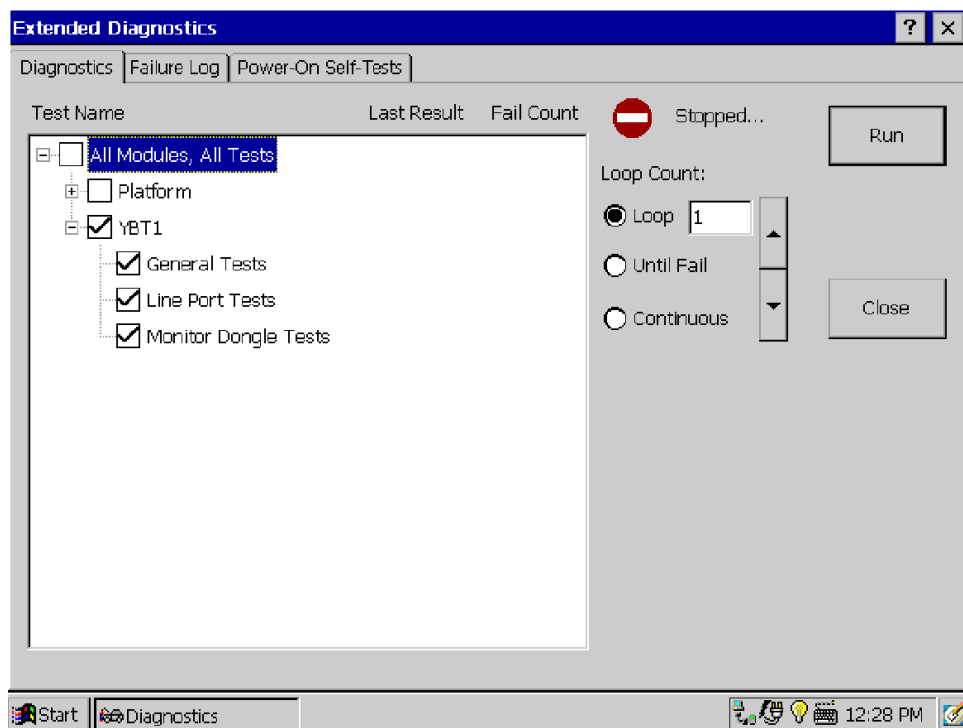

Figure C- 1: YBT1 diagnostic settings

11. Select the **LOOP** option button.
12. Set the loop count to **1** with the up/down arrow buttons.
13. Select **Run** to start the diagnostics.
14. Verify that each test executes and passes.
15. Select **Close** to exit the diagnostic system.

If you encounter any errors, open the **Failure Log** tab to obtain more information.

Test Descriptions

You must install the RJ48 Loopback Plug into the T1 Line Interface to run any of the following tests. See Figure 1-5 on page 1-10

General Tests

Verifies that the NetTek YBT1 software module loaded onto the Y350 NetTek Analyzer Platform is communicating with the YBT1 PC card.

Line Port Tests

Verifies that the Line port is functioning properly in both transmit and receive modes (through the loopback plug).

A transmitted reference pattern is compared to the received data pattern for an exact match. This test also verifies that the internal PC card hardware is functioning properly.

Monitor Dongle Tests

Verifies that the line interface amplifier is functioning properly.

Appendix D: Installing NetTek YBT1 Software

You can use the following methods to install, reinstall, or upgrade NetTek YBT1 software on the Y350 NetTek Analyzer Platform.

- **Serial Connection Method.** Uses a standard serial (RS-232) connection between a host PC and the NetTek Analyzer Platform.
- **Archive File Method.** Uses a PC memory card installed in the Y350 NetTek Analyzer Platform.

PC Requirements

This installation requires a desktop PC with CD-ROM drive and Windows 95, 98, or NT 4.0 operating system.

Installing Using a Serial Connection

This upgrade procedure requires a serial connection between the NetTek Analyzer Platform and a desktop PC.

1. Connect one end of the standard accessory Y350 NetTek Analyzer Platform RS-232 cable to the serial (COM) port on the desktop PC. See your computer documentation for the port location.
2. Connect the other end of the cable to the Y350 NetTek Analyzer Platform serial port. See the NetTek Analyzer Platform user manual for the port location.

If the desktop PC serial interface has already been configured to use Windows CE Services or Active Sync, you must disable the serial connection as explained below.

Disabling the Windows CE Services Serial Connection

If Windows CE Services is installed, you must do the following to disable the serial connection:

1. Right-click on the CE Services icon in the desktop PC status area; then select **Communications**.
2. In the Windows CE Services Properties dialog box, open the Communications tab.
3. In the Device Connections via Serial Port field, deselect **Enabled**. (Enable mobile device connection must already be selected to make this selection).
4. Select **OK**; then close the dialog box.

Disabling the Windows Active Sync Serial Connection

If Windows Active Sync is installed, you must do the following to disable the serial connection:

1. Right-click on the Active Sync icon in the desktop PC status area; then select **Connection Settings**.
2. In the Connection Settings dialog box, deselect the Allow serial cable or infrared connection to this COM port check box.
3. Select **OK** to close the dialog box.

Installing the YBT1 Software

To install the NetTek YBT1 software on the Y350 NetTek Analyzer Platform, do the following:

1. Shutdown the Y350 NetTek Analyzer Platform and remove the NetTek YBT1 PC card if installed.
2. Insert the NetTek YBT1 software installation CD-ROM into the desktop PC.
3. The disk should start up automatically. If it does not, run **ybt1setup.exe** in the CD-ROM Upgrade > Serial directory.
4. Follow the on-screen instructions provided by the upgrade wizard.

5. When the module upgrade is complete, shut down the NetTek Analyzer Platform and install the NetTek YBT1 PC card.
6. Start up the NetTek Analyzer Platform.

The NetTek YBT1 T1 Circuit Tester is now ready to use. To start the application, double-tap the YBT1 icon on the NetTek Analyzer Platform desktop or select **Start > Programs > NetTek > YBT1**.

NOTE. *When you have completed the upgrade process, be sure to re-enable your Windows CE Services or Active Sync serial connection.*

Installing Using an Archive File

To install the NetTek YBT1 software using an archive file, do the following:

1. Use a desktop PC to copy the archive file **ybt1.arq** in the Upgrade > Archive directory of the NetTek YBT1 software installation CD-ROM to a PC memory card.
2. On the NetTek Analyzer Platform, select **Start > Shutdown**; then select **Shutdown**.
3. Remove the NetTek YBT1 PC card if installed.
4. Insert the PC memory card containing the ybt1.arq file into the NetTek Analyzer Platform.
5. Start up the NetTek Analyzer Platform.
6. On the NetTek Analyzer Platform, select **Start > Programs > Tektronix Utilities > Module Upgrade**.
7. Follow the on-screen instructions to install the NetTek YBT1 software.
8. When the YBT1 module upgrade is complete, shut down the NetTek Analyzer Platform and remove the PC memory card.

9. Install the NetTek YBT1 PC card into NetTek Analyzer Platform.

10. Start up the NetTek Analyzer Platform.

The NetTek YBT1 T1 Circuit Tester is now ready to use. To start the application, double-tap the YBT1 icon on the NetTek Analyzer Platform desktop or select **Start > Programs > NetTek > YBT1**.



Index

Index

A

- Accessories, 1-3
 - optional, B-2
 - standard, B-1
- Address, Tektronix, ix
- Alarms
 - display
 - rolling, 2-21
 - set timespan, 2-21
 - indicator, 2-21
 - window
 - open, 2-17, 2-20
 - tab, 2-20
- Alarm/Error Count window, 2-26
 - open, 2-17
- Assemble product, 1-5
- Assembly, diagram, 1-5
- Audio, monitor DS0 channel, 3-15
- Automatic testing, 2-16, 3-9, 3-15
- Automatically start software, 1-9

B

- Base station, connecting to, 3-1
- Battery
 - indicator, 2-3
 - recycling, v
 - status, 2-3
- BER
 - counter, 2-25
 - testing, 3-15
- Bridge, input configuration
 - connecting to a circuit, 3-3
 - impedance, 2-12
 - option button, 2-12

Button

- open alarm/error count window, 2-17
- alarms history, 2-21
- open alarms window, 2-17
- automatic testing, 2-16
- desktop, 2-4
- drop DS0, 2-15
- errors history, 2-24
- open errors window, 2-17
- help, 2-7
- configure input/output, 2-12
- line code, 2-15
- loop code, 2-13
- loop down, 2-14
- loop up, 2-14
- pause a test, 2-11
- program, 2-5
- restart, 2-15, 2-19
- resume a test, 2-11
- Rx, 2-15
- show last result, 2-16
- open summary window, 2-16
- timed test, 2-16
- Tx, 2-14

C

Cable

- kit, optional accessory, B-2
- line interface adapter, 1-4
- restraint, 1-8
- test
 - RJ48 loopback, 1-4
 - RJ48-to-Alligator clip, 1-4

- RJ48-to-Bantam cross-wired,
 - 1-4
- RJ48-to-Bantam straight-wired,
 - 1-4
- RJ48-to-Bantam Y, 1-4
- Card, PC, 1-4
- CD-ROM, 1-4
- Certifications
 - EC, A-4
 - EMC, A-4
 - FCC, A-4
- Channel service unit, 3-1
- Clear settings, 2-15
- Codes, loopback, A-1
- Components, NetTek YBT1, 1-3
- Configure
 - input/output, button, 2-12
 - settings, 3-9
- Connecting the tester to a circuit,
 - 3-1
- Connections
 - alligator clip to 66 block, 3-3
 - bridge, 3-3
 - loopback, 3-6
 - monitor, 3-1
 - terminate, 3-4
 - to end of service line, 3-4
- Connector, loopback, 1-4
- Contacting Tektronix, ix
- Controls
 - front panel, 2-2
 - user interface, shared, 2-8
- Counter, BER, 2-25

D

- Data
 - collection, set resolution, 3-12
 - retransmit, 3-6
- Desktop

- icon, 2-4, 2-5
- overview, 2-3
- program button, 2-5
- start menu, 2-4
- status area, 2-5
- taskbar, 2-4
- Diagnostic tests, C-1
 - test descriptions, C-3
- Dimensions, external, A-2
- Disable
 - Windows Active Sync, D-2
 - Windows CE Services, D-2
- Display
 - alarms, 2-21
 - errors, 2-23
 - time span, 3-13
 - touch-screen, 2-1
- Dongle, 1-4
- Drop DS0
 - button, 2-15
 - overview, 3-13
 - set update interval, 3-14
- DS0, 2-15
 - activity graph, 3-8
 - view activity, 3-8
- DSX panel, connecting to, 3-1

E

- Electrical specifications, A-1
- Emissions
 - electromagnetic compliance, 1-6
 - PC card, 1-6
- Environmental specifications, A-3,
 - A-4
- Error
 - display, 2-23
 - set timespan, 2-24
 - indicator, 2-24
 - insertion, 2-25

Errors window
 open, 2-17, 2-23
 tab, 2-23

F

Failure log, C-2
Far end loop, set up, 3-19
Features, product, 1-2
File menu, 2-9, 2-11
Find information, start Help, 2-7
Frame synchronization indicator,
 2-17
Front-panel controls and indicators,
 2-2
Functional check, 1-10

H

Hardware reset switch, 2-2
Help
 icons, 2-7
 information, 2-7
 window, 2-11
Hide program, button, 2-5
History
 alarms/errors count, 2-26
 button
 alarms, 2-21
 errors, 2-24
 window
 open, 2-26
 sort data, 2-26
 tab, 2-26

I

Icon

?, 2-7
battery, 2-5
date and time, 2-5
desktop, 2-4, 2-5
keyboard, 2-5, 2-6
lightbulb, 2-5
power plug, 2-5
status, 2-5
toolbar, 2-11
 YBT1 start up, 1-9
Impedance, input, A-1
Indicator
 alarm, 2-21
 alarms/errors, 3-8
 display, 2-3
 error, 2-24
 frame synchronization, 2-17
 pattern synchronization, 2-18
 power on, 2-3
 T1 pulses, 2-17
 weak signal, 2-17
Information, getting help, 2-7
Injury, from lightning, 1-12
Input
 connections, 3-1
 panel, enter keyboard characters,
 2-6
Install
 PC card, 1-6
 software, 1-5, D-1
 from archive file, D-3
 from serial cable, D-1
Instructions, operating, 2-1
Instrument settings, 3-9

J

Jitter, specification, A-1

K

Keyboard

- (soft) input panel, 2-6
- special characters, 2-6

L

Lightning, avoiding personal injury,
1-12

Line

- code, detection, 2-15
- interface adaptor, PCMCIA, 1-4

Lock-up, software, 2-2

Log, failure, C-2

Loop, 3-19

- code, set up, 2-13
- down, button, 2-14
- up, button, 2-14

Loopback, 3-19

- codes, specifications, A-1
- input configuration
 - connecting to a circuit, 3-6
 - impedance, 2-12
 - option button, 2-12
- far end, 2-12
- plug, 1-4, 1-10, C-3
 - for performance check, 1-10
 - install, 1-10

Low battery indicator, 2-3

M

Manual, user, 1-4, B-1

Menu

- conventions, viii

file, 2-9, 2-11

help, 2-7

setup, 2-10, 2-11

start, 2-4

toolbar, 2-11

tools, 2-10, 2-11

Menu selections, 2-9

Monitor

audio data, 3-15

data path

customer side, 3-1

high-impedance connection,
3-3

network side, 3-1

input configuration

connecting to a circuit, 3-1

impedance, 2-12

option button, 2-12

T1 data, 3-1

N

NetTek Analyzer Platform, vii, 2-1

keyboard, 2-6

Network interface unit, 3-1

O

Online help, vii, 2-7

Open

alarms window, 2-20

errors window, 2-23

history window, 2-26

summary window, 2-19

Operating, instructions, 2-1

P

Pattern synchronization indicator,
2-18

Pause a test, button, 2-11

PC card, 1-4

emissions compliance, 1-6

installation, 1-6

product assembly, 1-5

Performance verification, 1-10,

C-1

test descriptions, C-3

Phone number, Tektronix, ix

Power

off, 1-10

on, 1-9

switch, 2-2

multiple functions, 1-11

Product

assembly, 1-5

features, 1-2

support, contact information, ix

Program button, 2-5

R

Receive level, 2-15

Recycle, battery, v

Reset

display previous test results, 2-16

hardware, 2-2

software, 1-11

Restart

a test, 2-15

button, 2-19

Restrain cables, 1-8

Resume a test, button, 2-11

Retransmit data, 3-6

Return to desktop, button, 2-4

Rolling display

alarms, 2-21

errors, 2-23

Rx status, 2-17

S

Safety

lightning, iii

summary, iii

Select, on-screen items, 2-1

Selections, menu, 2-9

Sensitivity, receiver, A-1

Serial cable, for software upgrade,
D-1

Service

panel, connecting to, 3-1

support, contact information, ix

Set up instrument, 3-9

Settings, 3-10

BER pattern, 3-11

change, 3-9

clock, 3-11

line code, 3-10

rolling display, collection resolu-
tion, 3-12

transmitter level, 3-12

Setup menu, 2-10, 2-11

Shared controls, user interface, 2-8

Show last result, 2-16

Shut down power, 1-10

Signal level, 2-15

Software

install, 1-5, D-1

CD-ROM, 1-4

install from, serial cable, D-1

reset, 1-11

start up, 1-9

upgrade, 1-5

version, viii

Specifications, A-1

- altitude, A-3
- electrical, A-1
- environmental, A-3, A-4
- humidity, A-3
- temperature, A-3
- Standby mode, 1-10
- Start, menu, 2-4
- Start up
 - power, 2-2
 - YBT1, 1-9
- Start YBT1 software, 1-9
- Status
 - area, desktop, 2-5
 - icons, 2-5
- Stylus, 2-1
- Summary window
 - open, 2-16, 2-19
 - tab, 2-19
 - test results, 2-19
- Suspend
 - analyzer activity, 1-10
 - front-panel, switch, 2-2
- Switch, power, 1-11

T

- T1
 - pulse indicator, 2-17
 - testing
 - connecting to a circuit, 3-1
 - overview, 3-7
- Tab
 - alarms window, 2-20
 - errors window, 2-23
 - history window, 2-26
 - summary window, 2-19
- Taskbar, desktop, 2-4

- Technical support, contact information, ix
- Tektronix, contacting, ix
- Terminate, input configuration
 - connecting to a circuit, 3-4
 - impedance, 2-12
 - option button, 2-12
- Test
 - automated, 3-15
 - BER, 3-15
 - diagnostic, C-1
 - nonintrusive, 3-3
 - results, summary window, 2-19
 - strategy, 3-7, 3-9
 - T1 data path, 3-1
- Time interval, 3-13
- Time span, 3-13
- Timed test, 2-16
- Toolbar
 - buttons, 2-11
 - icons, 2-11
 - menus, 2-11
- Tools menu, 2-10, 2-11
- Touch screen, 2-1
- Transmitter, set up, 2-14

U

- Upgrade, software, 1-5, D-1
- URL, Tektronix, ix
- User manual, 1-4

V

- Verify performance, 1-10, C-1
- Version, software/hardware, viii
- View DS0 activity, 3-8

W

Weak signal indicator, 2-17

Web site address, Tektronix, ix

Weight, A-2

Window

alarm/error count, 2-26

alarms, 2-20

errors, 2-23

history, 2-26

start up, 2-19

summary, 2-19

